

TB-2/3

Industrial Case Taping System

User Guide

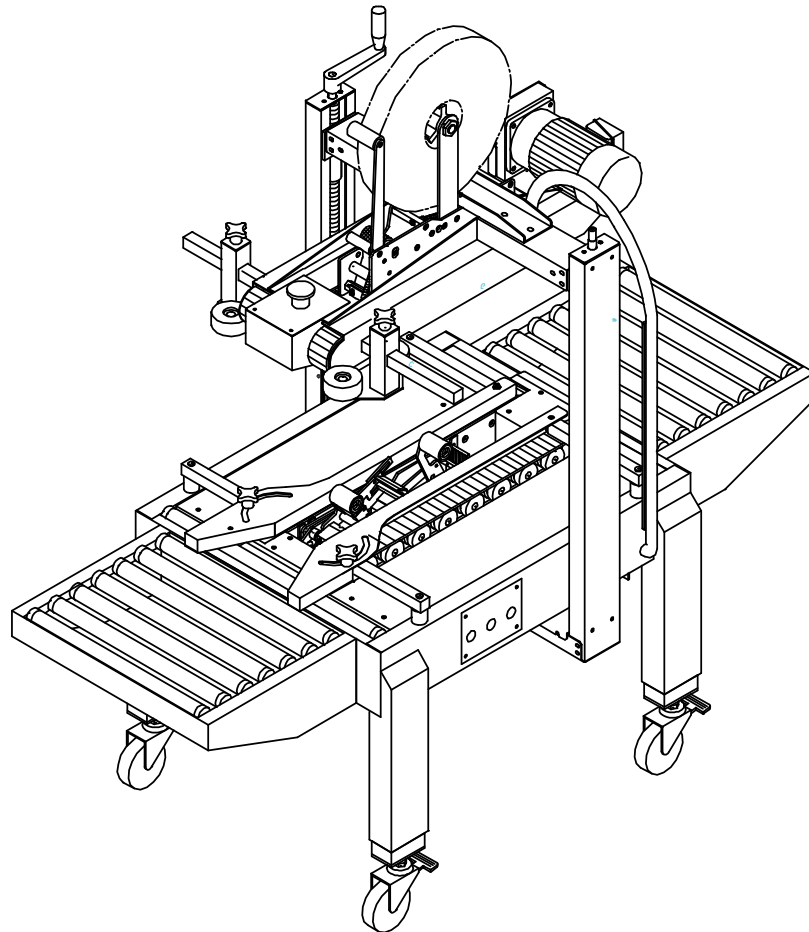

EASTLEY[®]

TB-2/3

Industrial Case Taping System

User Guide

Revised 04/13/2018

P/N 5001684 Rev B

Copyright and Trademarks

Copyright ©2012-2018 Eastey Enterprises
All rights reserved. All trademarks and brand names
are the property of their respective owners.

Eastey Enterprises, Inc.
7041 Boone Ave. N.
Brooklyn Park, MN 55428

Phone: (763) 428-4846; Fax (763) 795-8867; 1-800-877-9344

www.eastey.com

Contents:

- Safety 7**
 - Explanation of Symbols..... 8

- Introduction 9**
 - General System Description..... 9
 - Specifications 10
 - Options..... 10
 - Dimensions 11

- Installation 12**
 - Location Requirements 13
 - Install Front and Rear Tables 14
 - Next Steps..... 14

- Operation 15**
 - Loading the Tape Cartridges..... 15
 - Check Tension..... 16
 - Thread Tape 16
 - Main Spring 18
 - Power 19
 - Control Panel 19
 - Emergency Stop..... 20

- Adjustments 21**
 - Height and Width Adjustments 21

- Maintenance 24**
 - Rollers 24
 - Cutting Knives 24

- Troubleshooting 25**

- Parts List..... 27**
 - Electrical..... 27
 - Upper Taping Seat 31
 - Vertical Column..... 34
 - Lower Taping Seat 36
 - Machine Body 39

- Warranty Statement 41**

- Customer Support..... 43**

Safety

General Safety Precautions

Before installing, operating or servicing this equipment, please read the following precautions carefully:

- This machine is equipped with moving belts. Do not place hands near the rear of this unit when the belts are moving as fingers may be pinched where belts enter the frame. We suggest the use of a roller-type exit conveyor or pack table for your cases. Always remove boxes after they clear the exit end of the machine.
- Observe caution when near the tape applying cartridges or when threading tape. The knife is very sharp, automatically operated, and is linked to the wipe down rollers.
- Always disconnect electrical power before attempting maintenance for any electrical or moving parts. Do not attempt to open or work on the electrical box, junction boxes or other electrical components of the unit without first disconnecting power to the machine. Electrical shock hazard exists if power is not disconnected.
- Do not by-pass any factory-designed safety features such as knife guards, interlocks, switches, etc.
- Do not place hands or body inside the confines of the machine unless the head mechanism is securely fastened, and the electrical supply is shut off.
- To minimize the potential for personal injury, always be sure that the machine operators and others working on the machinery are properly trained in the correct usage of the equipment and properly instructed regarding safe operation.
- Never provide service or clear a box jam when the machine is running.
- When feeding a box into the unit, always hold down the box top and present the box to unit. Release hands as soon as the belts begin to take the box.
- Do not wear loose clothing such as ties, scarves, jewelry etc. Long hair should be pulled back and/or covered while operating this machine.

Explanation of Symbols



Caution sign or Safety Alert symbol. Indicates caution, be alert, Your safety is involved. Knowledge of safe operation is required.

Caution indicates a hazardous situation which, if not avoided, could result in minor or moderate injury or damage to equipment or surroundings.

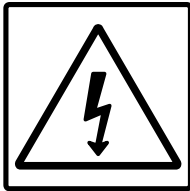

Electrical hazard. Indicates electrical danger. Only a trained electrician can uncover the electrical panel or box.



Warning symbol. Indicates a hazardous situation which, if not avoided could result in death or serious injury.

A warning indicates a situation or condition potentially more severe than indicated by a caution message but not imminent as a danger message.

This symbol is associated with warnings for conditions as shown below.

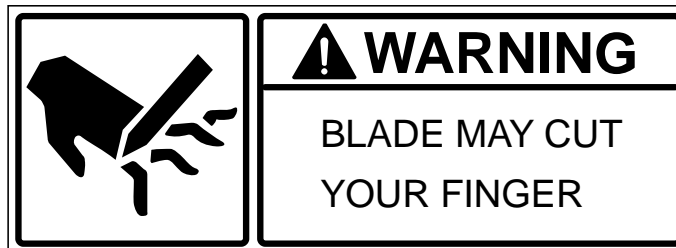

Introduction

General System Description

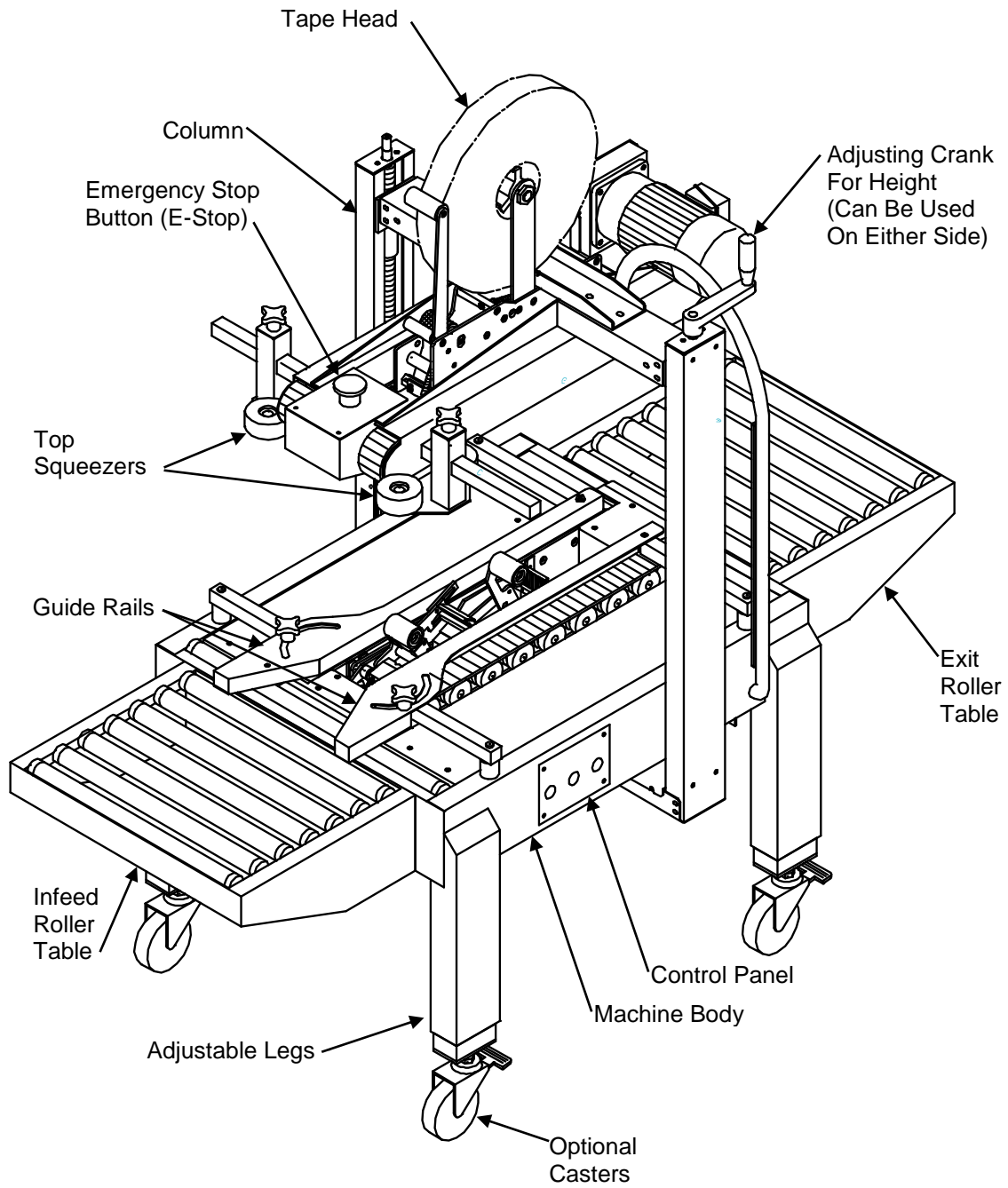

Specifications

Model	TB-2/3
Tape	2 inch (5 cm)
Belt speed	80 feet/min (24.5 m/min)
Capacity	(L) 5 inches (12.7 cm) to unlimited (W) 6 inches to 20 inches (15.3 cm to 50.8 cm) (H) 6 inches to 20 inches (15.3 cm to 50.8 cm)
Consumption	450 W
Machine size	(L) 64.5 inches (163.7 cm) (W) 29.7 inches (75.4 cm) (H) 74.5 inches (189.2 cm) MAX. with upper tape head at full-capacity 62.5 inches (157.5 cm) MAX. less upper tape head
Machine net weight	350 lbs. (159 kg)

Options

- 3" tape head

Dimensions

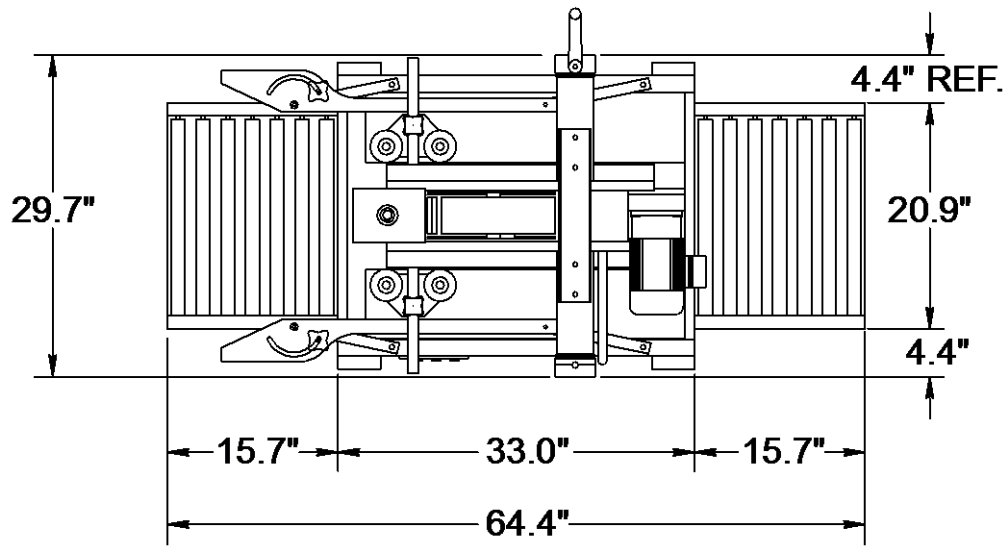

Top View

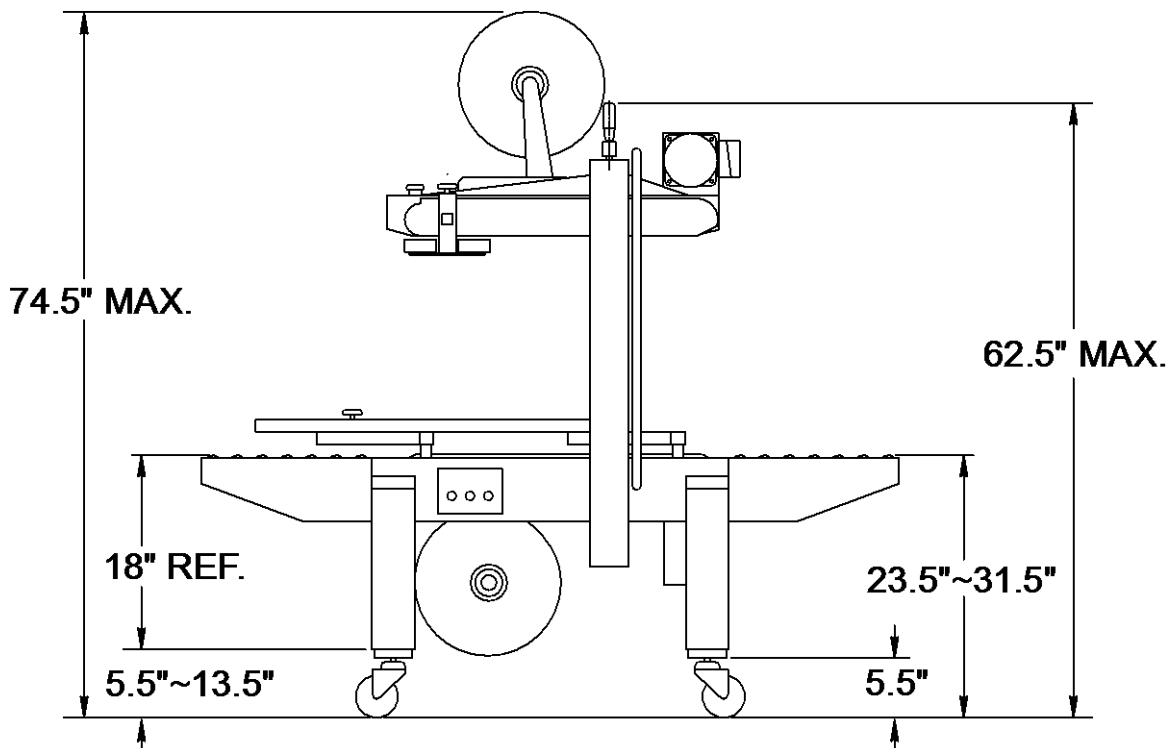

Side View

Installation

Carefully unpack the outer carton. Avoid damaging the machine body.

Remove the banding straps that secure the Case Taper to the shipping pallet. Lift the Case Taper off the pallet.

CAUTION! The TB-2/3 Case Taper is a very heavy piece of equipment and will require a forklift or floor crane or several people to move safely off the shipping pallet.

Install the four (4) casters on the case taper legs. Thread each caster into the bottom of each leg while supporting the carton sealer. (Refer to the illustration below for casters installation assembly and adjustment.)

To adjust the leg height, loosen the screws on each leg and slide the insert up or down. When the leg is at the desired height, retighten the adjustment screws to secure the leg height.

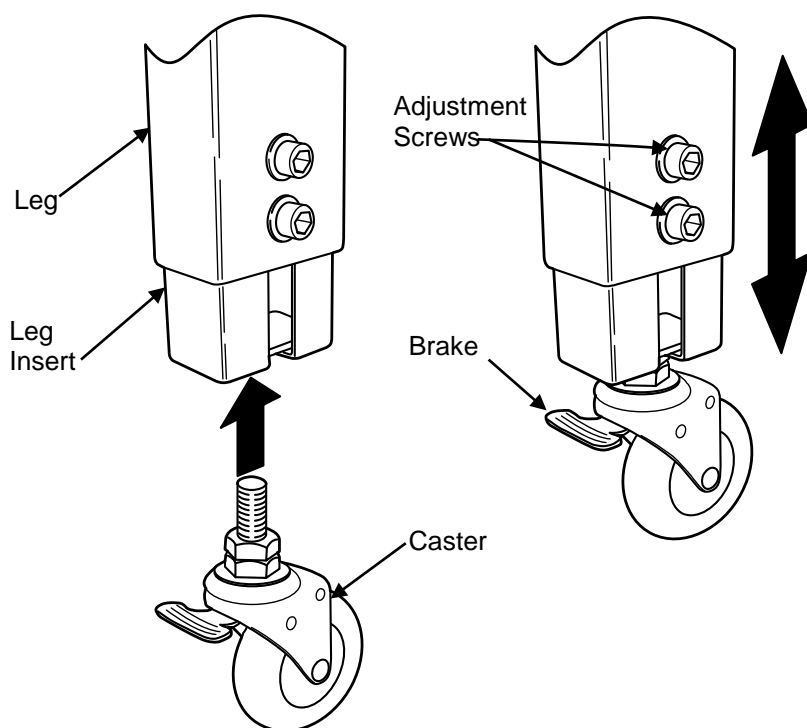

CAUTION! The Case Taper must be lifted off the floor to install the casters. Use proper equipment when lifting or moving the case taper. Ensure the Case Taper is secure and will not shift while installing the casters or adjusting leg height.

To move the TB-2/3 Case Taper to the desired location, you will need to use a pallet jack or fork lift. Optional locking casters allow the case taper to be moved easily over a smooth flat surface.

Location Requirements

When installing the TB-2/3 Case Taper please be aware of the following considerations:

1. The mounting surface is flat and level.
2. Conveyor or packing table height.
3. Alignment with packaging line.

When the TB-2/3 Case Taper is positioned in the operating location you will need access to:

1. The power switch and control panel on the side of the machine and E-Stop on the upper belt and tape head seat.
2. Height adjustment for the upper belt, and width adjustments of upper squeezers and lower guide rails.
3. Tape loading (Both upper and lower tape cartridges).

Roller tables are provided standard at both the in-feed and exit ends of the case taper. A packer can fill boxes and close the flaps at the in-feed roller table before feeding boxes into the case taper, and then pick up boxes that have been sealed from the exit roller table.

If the case taper is part of a longer packaging line, take into consideration the table and conveyor height in relation to adjacent machinery.

It is essential that the table and conveyor be at the machine bed height.

The machine should be placed on a flat, level floor so that it does not rock or move. We recommend that the machine be securely locked in place when used.

Install Front and Rear Tables

Front and rear tables are identical and therefore interchangeable. Temporarily loosen socket head cap screws at the locations shown in the following illustration. Align the keyhole slots in the table flanges with the loosened cap screw heads and position the end table so rollers are level with rollers in the case taper body, then re-tighten cap screws to secure table. Install one table at each end (front and rear) of the case taper body.

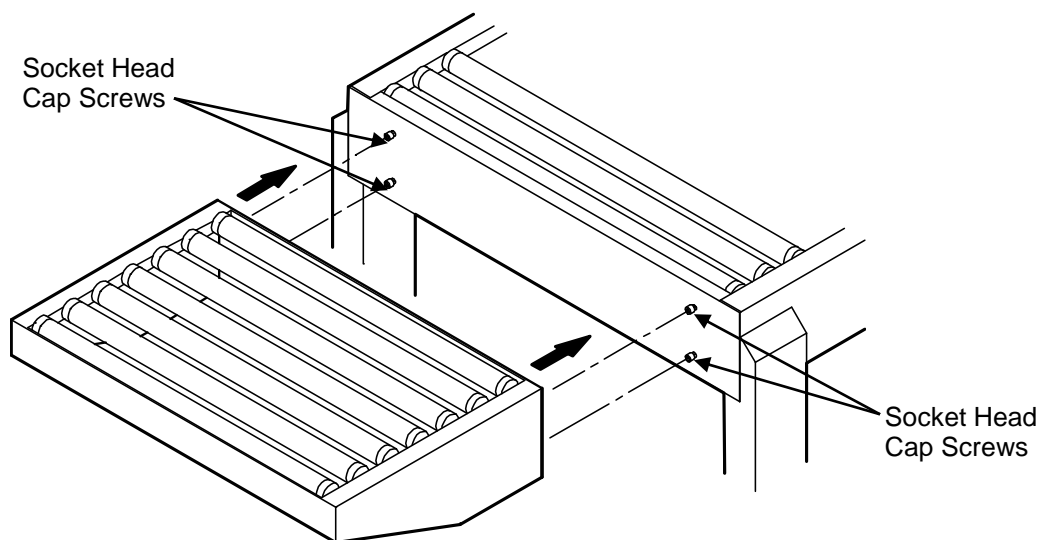

Next Steps

Follow instructions in the Operation section for instructions to load the tape cartridges in the upper and lower tape heads.

If tape heads have not been loaded with tape, load the upper and lower tape heads with tape. (One roll each; follow instructions provided in the Tape Cartridge User Guide.)

Refer to the Adjustments section for instructions to make necessary height and width adjustments that must be made for operation of the box taper.

Refer to the Operation section for instructions to power up, operate, and shut down the machine.

Operation

Loading the Tape Cartridges

Turn the main power switch to “Off” and disconnect the power.

CAUTION! To avoid personnel injury, remove the tape cartridge before loading tape.

When handling the tape cartridge be careful to avoid contact with the tape cutting blade.

After the taping cartridge has been removed push the tape roll onto the tape core assembly.

NOTE: Make sure the tape roll is pushed all the way on the tape core assembly.

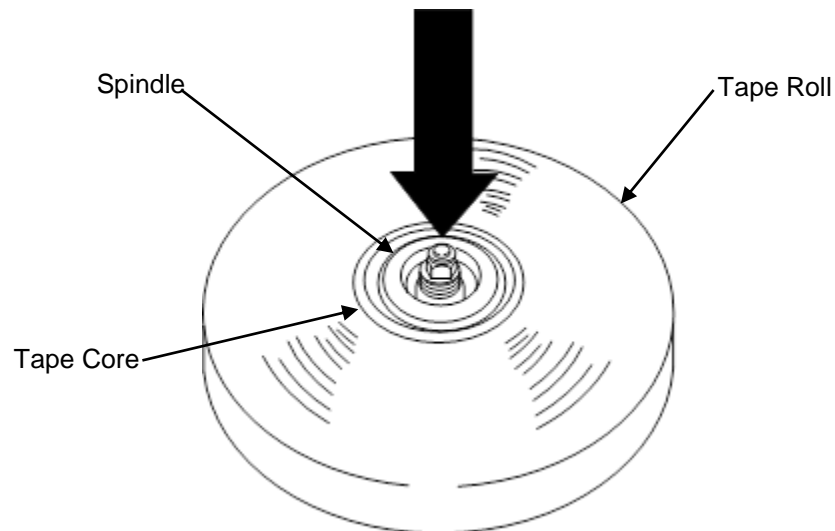

Check Tension

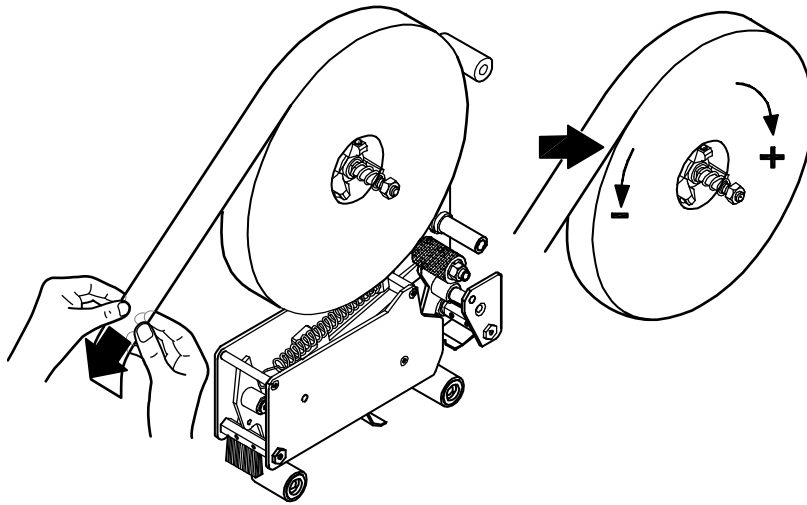

Check the tape for correct tension. Tighten or loosen the tape core holder to adjust tension.

Thread Tape

Carefully thread the new tape through the rollers in the tape head as shown in the applicable diagram in the Tape Head User Guide provided with the tape head.

For convenience, diagrams for threading tape in the Eastey-EX Tape Head and EZ-EX Tape Head are provided on the following page. Follow the diagram that applies for your tape head, depending on the tape head model and position on the taper.

Easteey-EX Tape Head

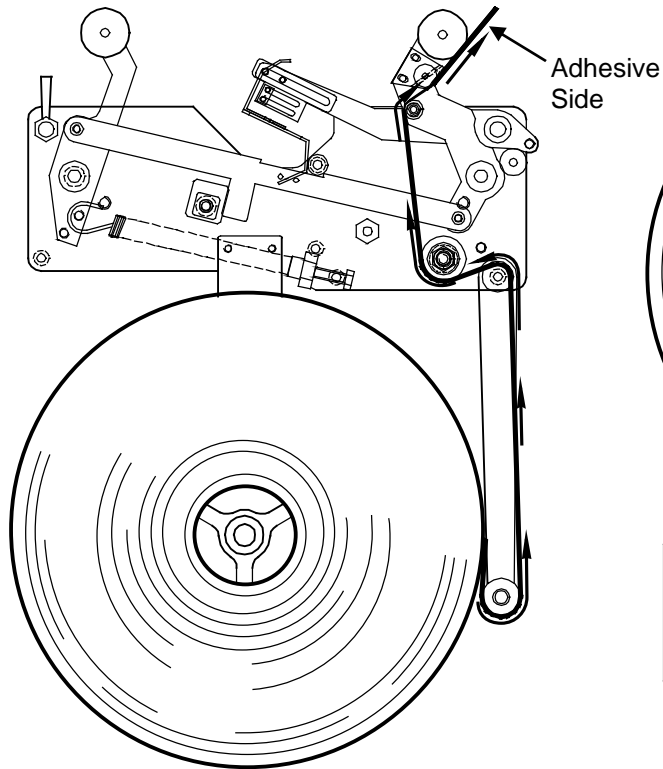

Bottom Cartridge

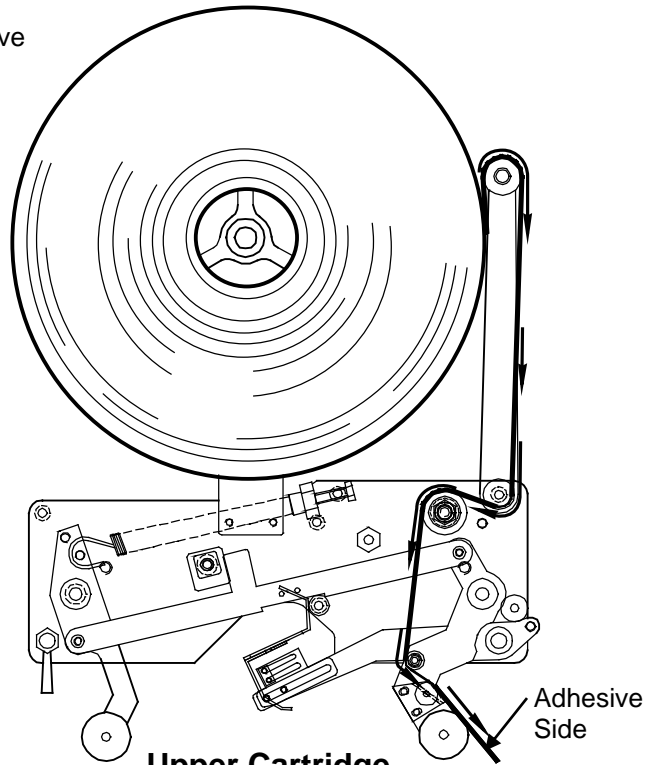

Upper Cartridge

EZ-EX Tape Head

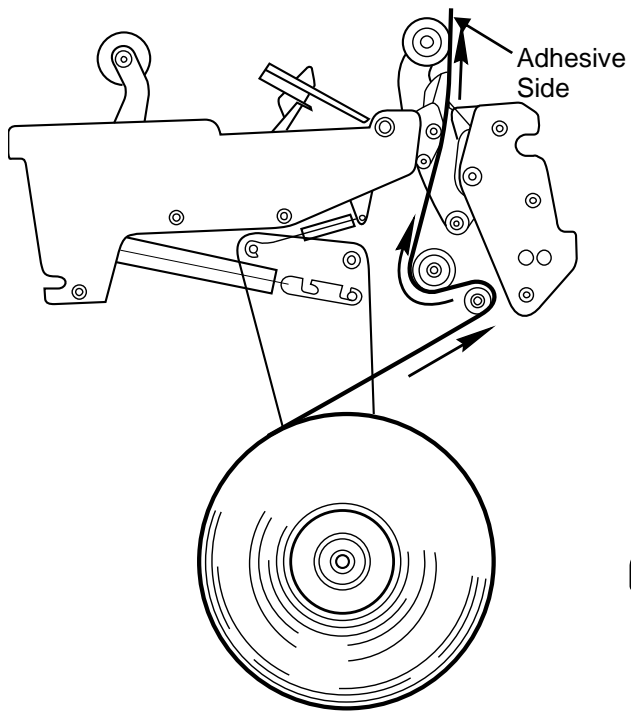

Bottom Cartridge

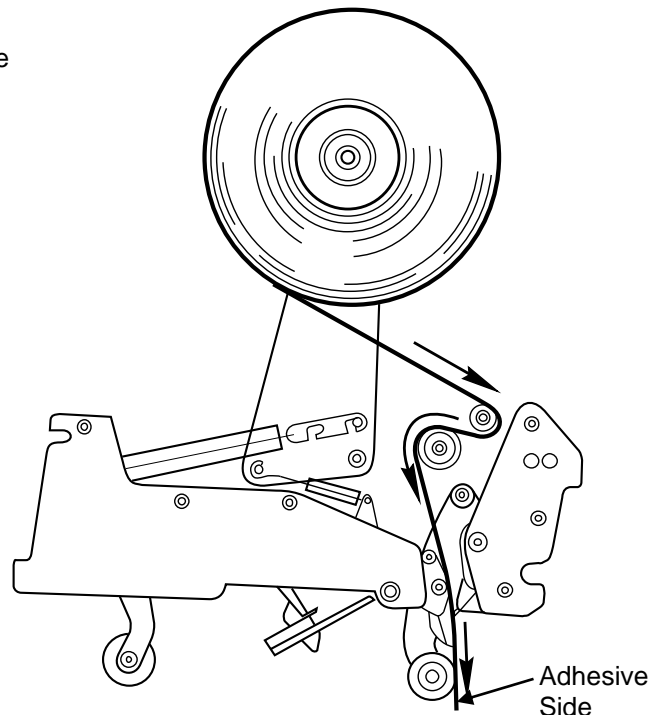

Upper Cartridge

Center Tape — Eastey-EX Tape Head only

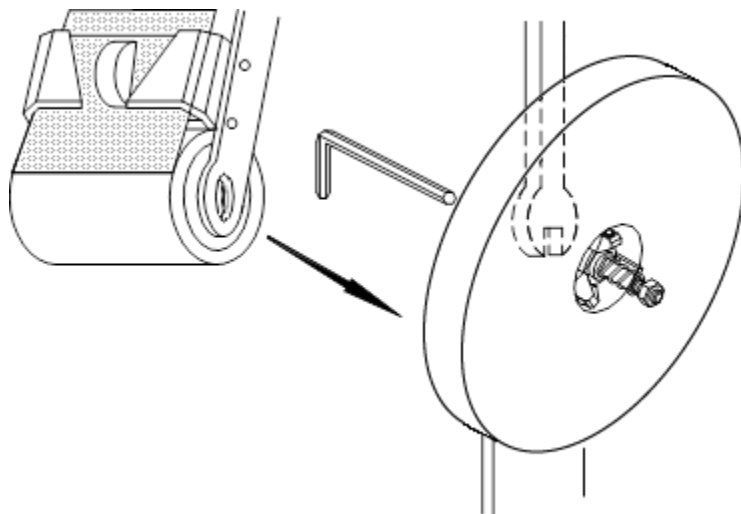

Make sure the tape is centered on all the rollers.

There are several rollers in the tape cartridge where the tape alignment should be checked to verify the tape stays on center as it is being dispensed.

Return the tape cartridge to the operation position.

Main Spring

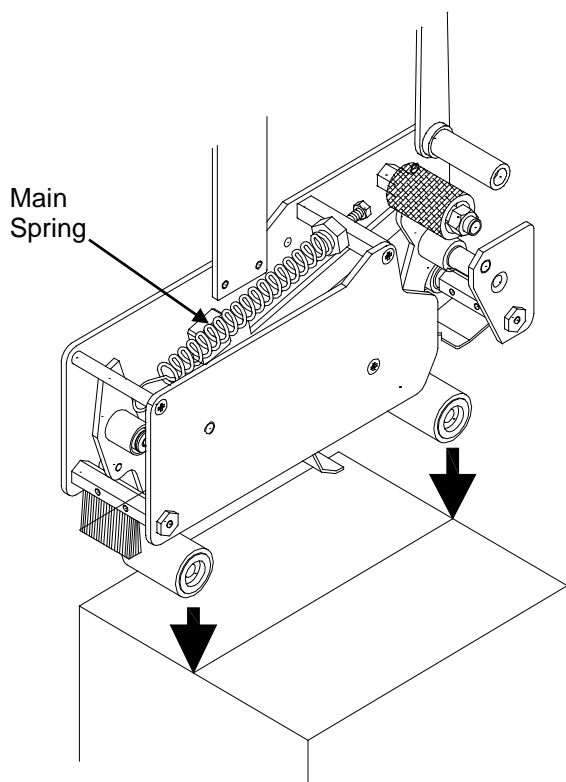

For sealing light weight boxes, decrease the main spring tension. For heavier boxes, increase the main spring tension.

When setting tension for the rollers, consider the amount of pressure on the box flaps required to make the seal. Cartons completely filled to the top with product may require more pressure on top and bottom seams when applying tape than partially-filled cartons, where excessive pressure could possibly crush the carton.

Power

Plug the power supply cord into a properly wired and grounded outlet.

Press the Start button.

CAUTION! When the power is turned on be aware of moving parts and belts

When the main power switch is On and there is power to the carton sealer, the Power Indicator light illuminates.

Control Panel

When the main power switch is in the "ON" position the power lamp should be illuminated.

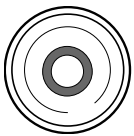
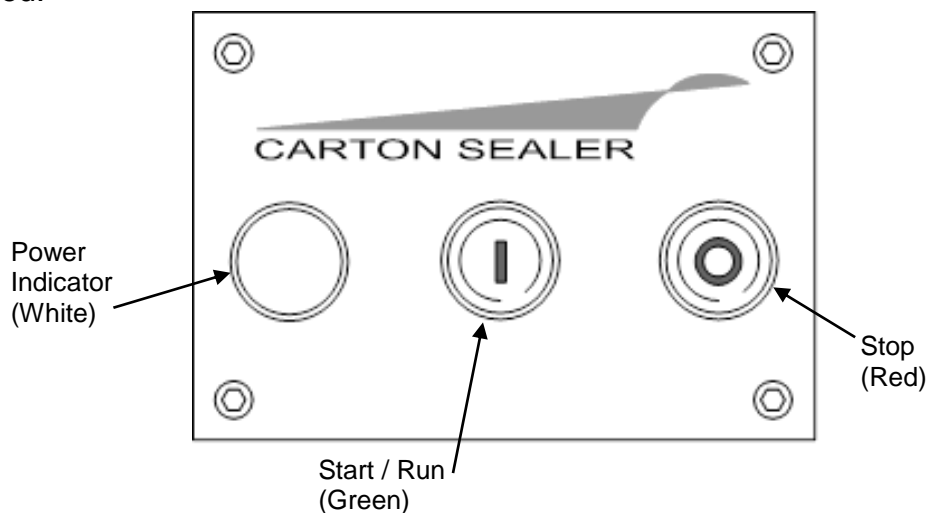

Stop Button (Red)
Press to stop motors and belts.



Start / Run Button (Green)
Press to start motors and belts.

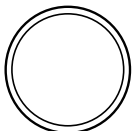

Power Indicator Lamp (White)
On when carton sealer is in operation.
Off when carton sealer is not in operation.

Emergency Stop

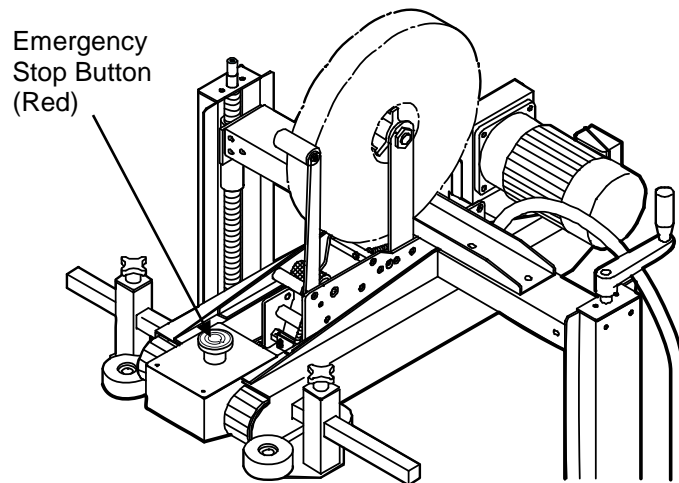

Emergency Stop Button (Red)

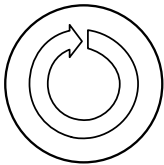

Press the button for emergency stop.

To reset the Emergency Stop button once the emergency condition has been cleared and it is safe to operate the machine again, press the Emergency Stop button in while turning it approximately a quarter-turn in the direction of arrows.

Adjustments

Height and Width Adjustments

With the power off, place an appropriate size carton in the Case Sealer.

Height Adjustment

Use the height adjustment crank to set the upper tape head to the correct box height.

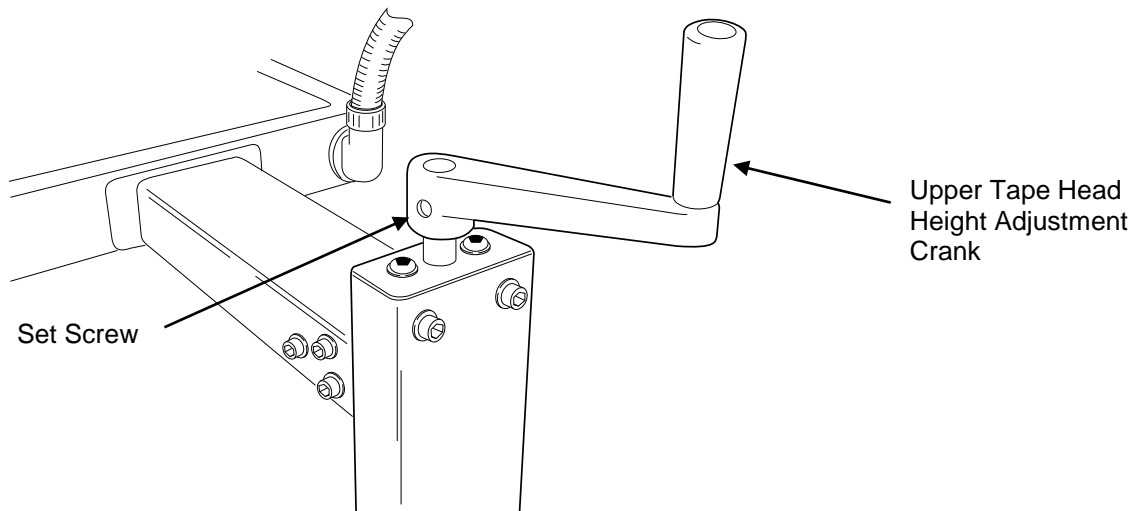

The height adjustment crank can be mounted on either side of the machine by loosening the set screw and removing the crank. Mount the crank on the opposite side and re-tighten the set screw.

Width Adjustments

Loosen the locking knobs on the top squeezer alignment rollers to set the top width to the correct box width and re-tighten the locking knobs. This will insure the box stays centered.

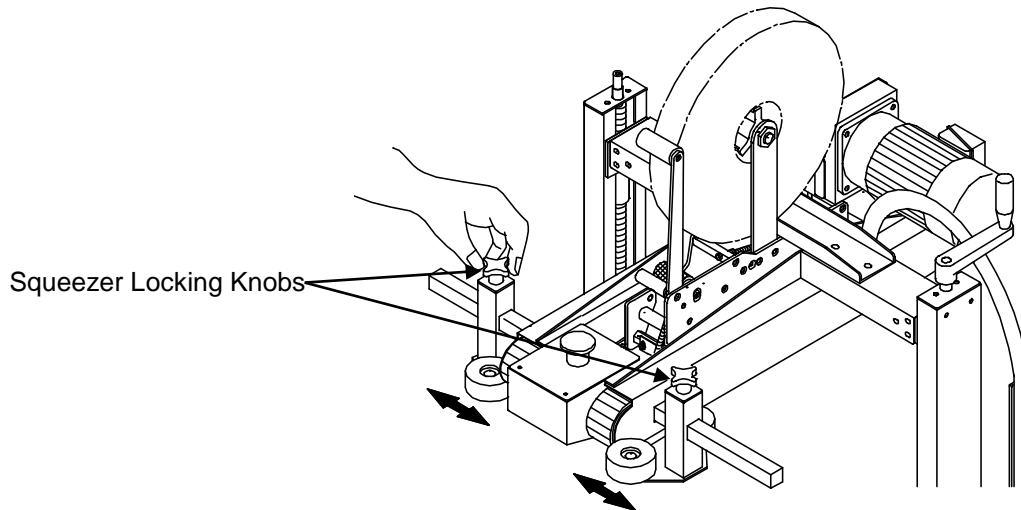

Knobs on the side rails below the squeezer locking knobs work similarly. Loosen the locking knob to reposition the side rails to the correct package width and then retighten to secure in position.

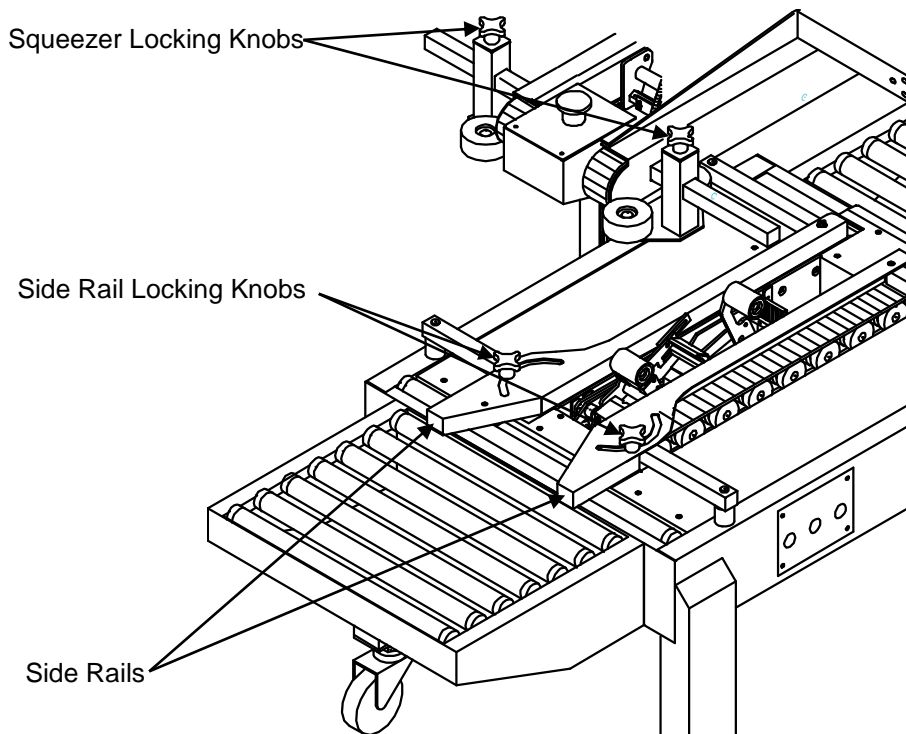

Machine Body Height Adjustment

To adjust the leg height, loosen the screws on each leg and slide the insert up or down. When the leg is at the desired height, retighten the adjustment screws to secure the leg height.

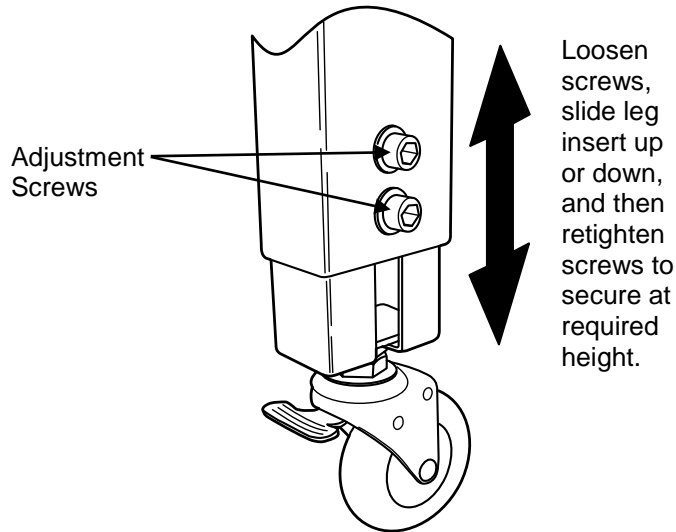

CAUTION! Ensure the case taper is secure and will not shift while adjusting leg height.

Tape Head Adjustment — Refer to Tape Head User Guide.

Refer to instructions in the Tape Head User Guide that is provided with the tape head for instructions regarding adjustment information for the tape head.

Maintenance

The TB-2/3 Industrial Case Taping System will provide many hours of maintenance free operation. There are a few items that may require attention from time to time.

Rollers

Make sure rollers stay clean and grease free. If you should have to clean the rollers simply wipe them down with a clean lint free cloth. If a more thorough cleaning is necessary wipe the rollers down with a mild detergent and water and let dry. **Never use harsh or abrasive cleaners or chemical agents when cleaning the rollers.**

Cutting Knives

Occasionally inspect the cutting knives to ensure they are clean and free of adhesive residue. Make sure the cutting knife is sharp by inspecting cuts in the tape. Cuts should be straight and neat. If the quality of cuts is eroding, the knife blade is dull and should be replaced.

Changing Knife Blades — Refer to Tape Head User Guide

Turn off and unplug the taper. It is not necessary to remove either tape head to change the blade. Refer to the Tape Head User Guide provided with the tape head for instructions for changing the knife blades.

CAUTION! Always be aware of the cutting edges while replacing the knife blades. Handle the knife blades carefully.

Troubleshooting

Problem	Possible cause	Solution
Taper will not start.	Machine is not connected to power. The Emergency Stop button is pressed in. Start button has not been pressed. Blown Fuse.	Check power input. Verify power connection. Release the Emergency Stop button. Press the Start button. Check power/overload condition, then replace fuse if blown.
Machine is not operating.	Machine has inadequate electrical power or power is not connected.	Verify system power meets specification requirements.
Machine cannot tape cartons.	The side rails or squeeze rollers are not correctly adjusted for the box size.	Check the width of the side rails and squeeze rollers and adjust as required for the box size.

Problem	Solution
Stuck carton	<ul style="list-style-type: none"> • Check drive belt width adjustment. • Check for proper height adjustment.
Uneven or poor tape cuts	<ul style="list-style-type: none"> • Adjust knife arm spring tension. • Adjust wipe roller spring tension. • Replace cutting knives.
Uneven Tape Leg on Front	<ul style="list-style-type: none"> • Tape tension is too low. Tighten the one-way clutch roller and/or the tape core. • Adjust the one-way clutch roller in the slot so it is slightly beyond the front wipe roller. • Adjust the tape leg length. See Tape Leg Adjustment section.

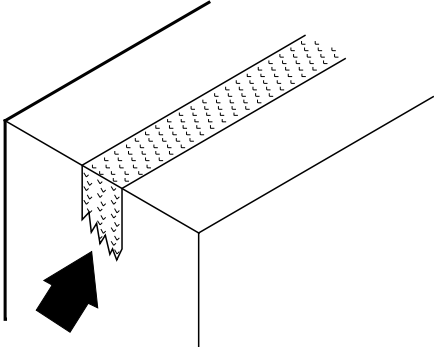
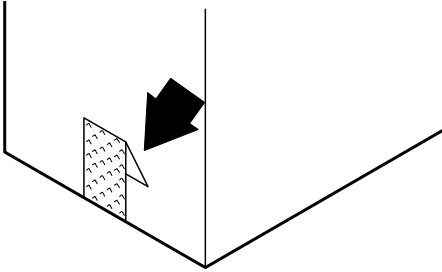
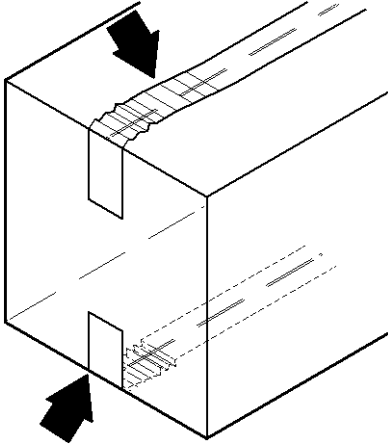
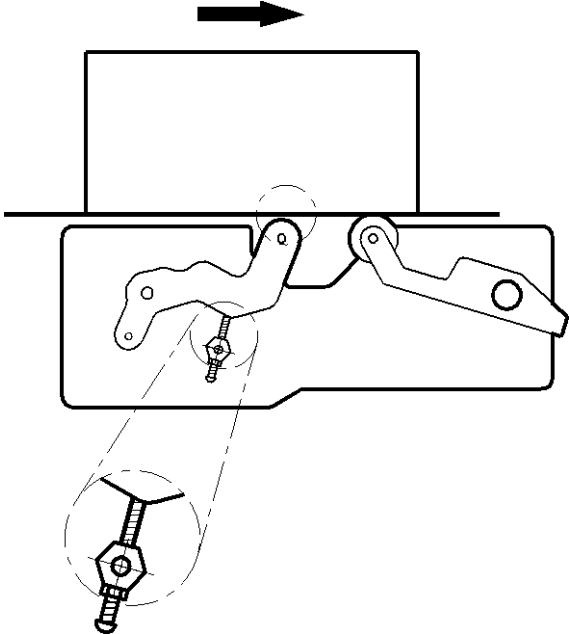
Problem	Solution
<p>Uneven or Torn Tape</p> 	<ul style="list-style-type: none"> • Blade is dull. Replace Blade. • Tape tension is incorrect. Increase tension. • Clean and adjust blade. • Blade mounted incorrectly or backwards. • Knife arm spring is worn. Replace knife arm spring. • Adjust cartridge height.
<p>Tape Folding</p> 	<ul style="list-style-type: none"> • Check that all rollers turn freely. • Check to be sure tape is threaded properly on front roller (refer to Tape Head User's Manual).
<p>Tape Curling and Bunching Up — Eastey EX Tape Head Only</p> 	<p>Eastey-EX Tape Head Only</p> <ul style="list-style-type: none"> • Adjust the tape cartridge height (approximately .06 inches from box)  <ul style="list-style-type: none"> • Check tape tension set by the spring tension at the tape core.

Parts List

Electrical

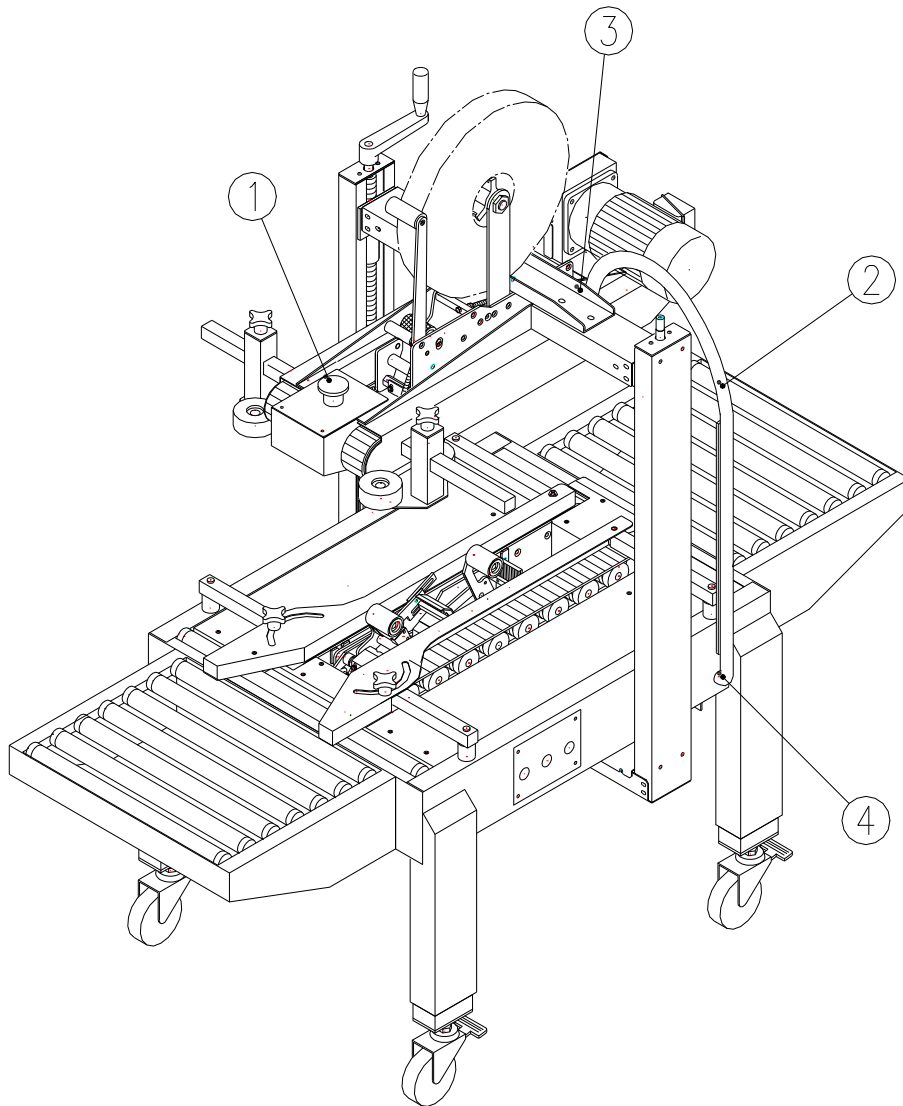

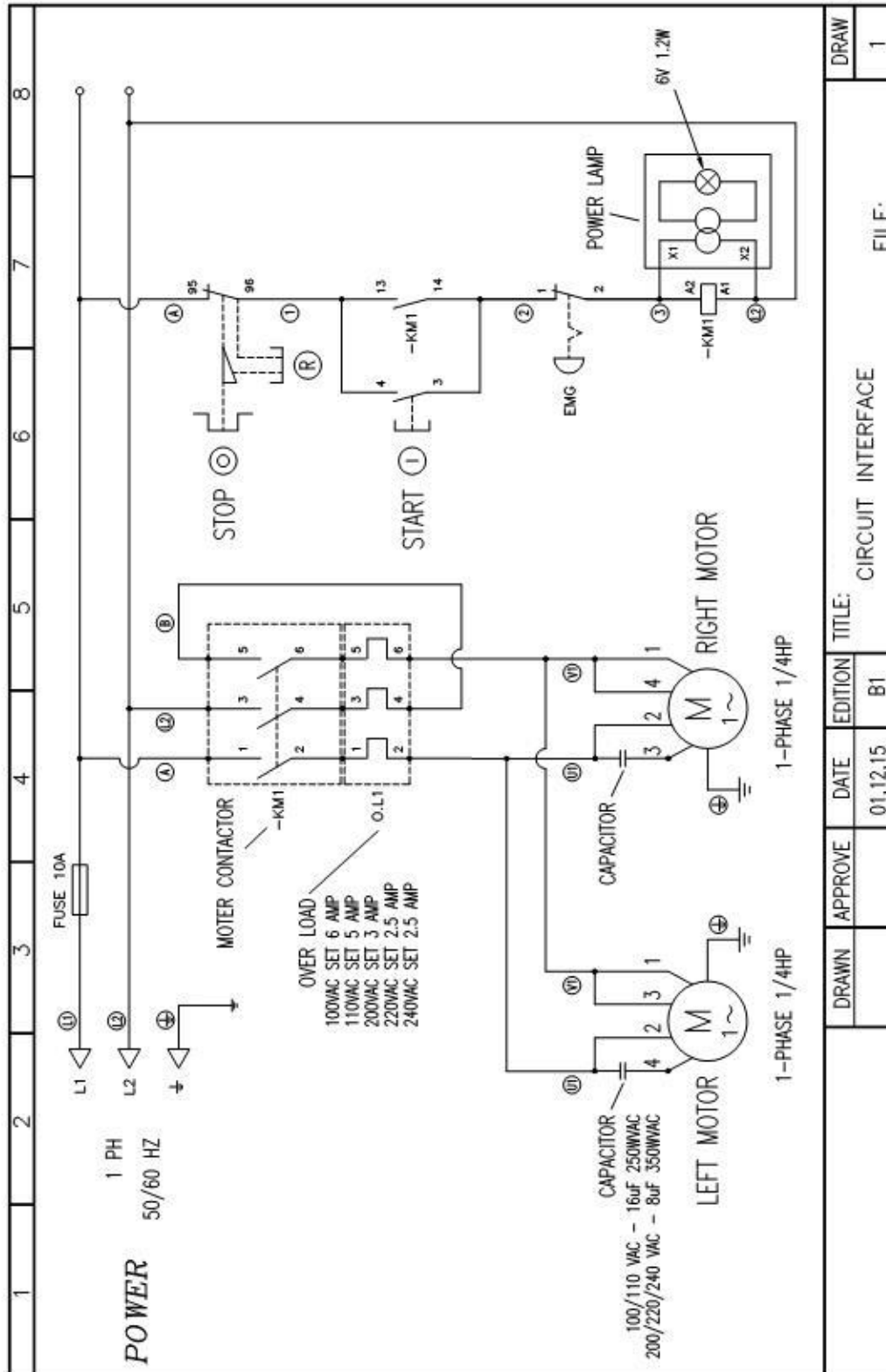

DRAWN	APPROVE	DATE	EDITION	TITLE	FILE:	DRAW
		01,12,15	B1	CIRCUIT INTERFACE		1

ITEM	PART NO.	DESCRIPTION	Q'TY
1	7155BC01	EMG. SWITCH	1
	7158BZ02	BUTTOM SEAT CONTACTOR NCx1	1
2	7066P001	1/2" CONNECTOR	1
3	7065C062	1/2" PROTECT TUBE	1
4	7066C064	1/2" 90° CONNECTOR	1
11	70560601	TERMINAL BLOCKS TB6P	1
12	7032SW01	CONNECTOR	1
13	71570002-01	BREAKER LC1-D09F7 110V	1
	71570003-01	BREAKER LC1-D09M7 220V	1
14	71570002-02	OVERLOAD PROTECTOR LR3-D106(4-6A)	1
	71570003-02	OVERLOAD PROTECTOR LR3-D086(2.5-4A)	1
15	7155AL01	BUTTON	1
16	7155AA03	BUTTON	1
	7158AZ01	CONTACTOR NOX1	1
17	7151AV01	POWER LAMP 220V	1
	7150AV01	BLANKIG PLUG	1
	7151AV02	POWER LAMP 110V	1
	7150AV01	BLANKIG PLUG	1
18	7025AG16	FIXED SEAT	4
19	72561003	FUSE	1
	7250FH01	FUSE SEAT	1
20	7155AL01-1	ENCLOSURE	1

Upper Taping Seat

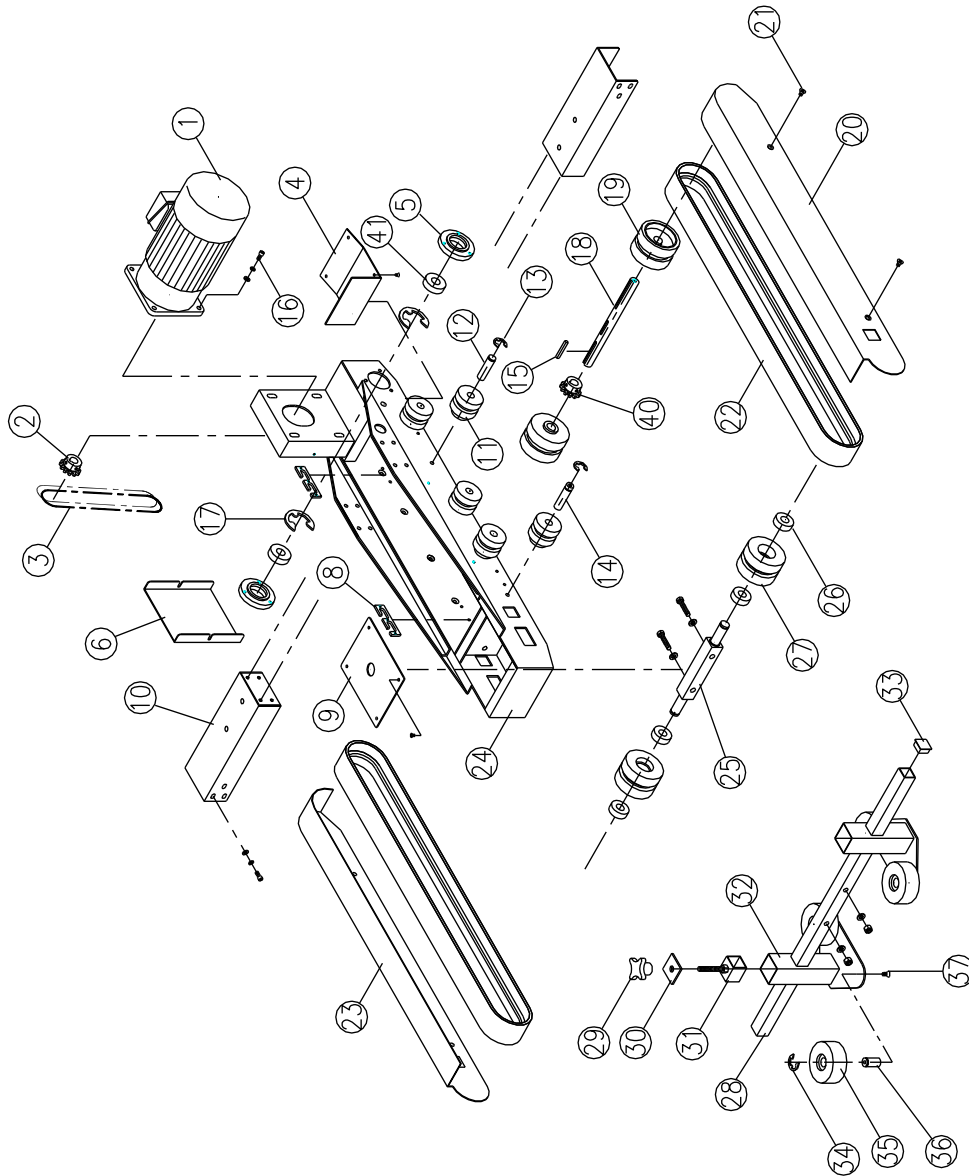

32 Illustrated Parts List

ITEM	PART NO.	DESCRIPTION	Q'TY
1	745111L1	MOTOR 110V/60HZ,T18:1	1
	745122L1	MOTOR 220V/60HZ,T18:1	1
	745122L2	MOTOR 220V/50HZ,T15:1	1
	745124L2	MOTOR 240V/50HZ,T15:1	1
	745138L1	MOTOR 380V/50HZ,T15:1	1
	745140L1	MOTOR 400V/50HZ,T15:1	1
	2	CA331200	MOTOR SPROCKET WHEEL
3	3240S35C	CHAIN	1
4	CA130600	COVER PLATE (2")	1
	CA130610	COVER PLATE (3")	1
5	CA131000	BEARING SEAT	2
6	CA331100	MOTOR COVER	1
7			
8	CA100300	B-PLATE	4
9	CA130300	COVER PLATE (2")	1
	CA130310	COVER PLATE (3")	1
10	CA130200	SUPPORT SET (2")	2
	CA130210	SUPPORT SET (3")	2
11	CA301300	PLASTIC PULLEY	10
12	CA301400	PULLEY SHAFT	6
13	11301200	RING STW-12	10
14	CA130700	PULLEY SHAFT	4
15	10925300	KEY	1
16	10100825	SCREW M8 x 25L & S.W & W	4
17	11314000	RING RTW-40	2
18	CA331400	DRIVER SHAFT(2")	1
	CA331410	DRIVER SHAFT(3")	1
19	CA301900	PULLEY DRIVER	2
20	CA1312R0	BELT COVER	1
21	10200610	SCREW M6 x 10L & S.W & W	4
22	CA331900	BELT	2
23	CA1312L0	BELT COVER	1
24	CA13010A	UPPER TAPING SEAT (2")	1
	CA130110	UPPER TAPING SEAT (3")	1

ITEM	PART NO.	DESCRIPTION	Q'TY
25	CA330800	ADJUSTABLE SHAFT(2")	1
	CA330810	ADJUSTABLE SHAFT(3")	1
26	30300030	BEARING 6003ZZ	4
27	CA301100	PULLEY FOLLOWER	2
28	CA101000	SUPPORT BAR	1
29	CA101600	HANDLE KNOB	2
30	CA100900	LOCKING BRACKET	2
31	CA131300	SCREW KNOB	2
32	CA130400	COMPRESSION ROLLER SEAT	2
33	91350001	RUBBER PLUG	2
34	11301700	RING STW-17	4
35	CA100600	COMPRESSION ROLLER	4
36	CA100700	COMPRESSION ROLLER SHAFT	4
37	10140610	SCREW M6 x 10L	4
40	CA331300	MOTOR SPROCKET WHEEL	1
41	30302030	BEARING 6203ZZ	2

Vertical Column

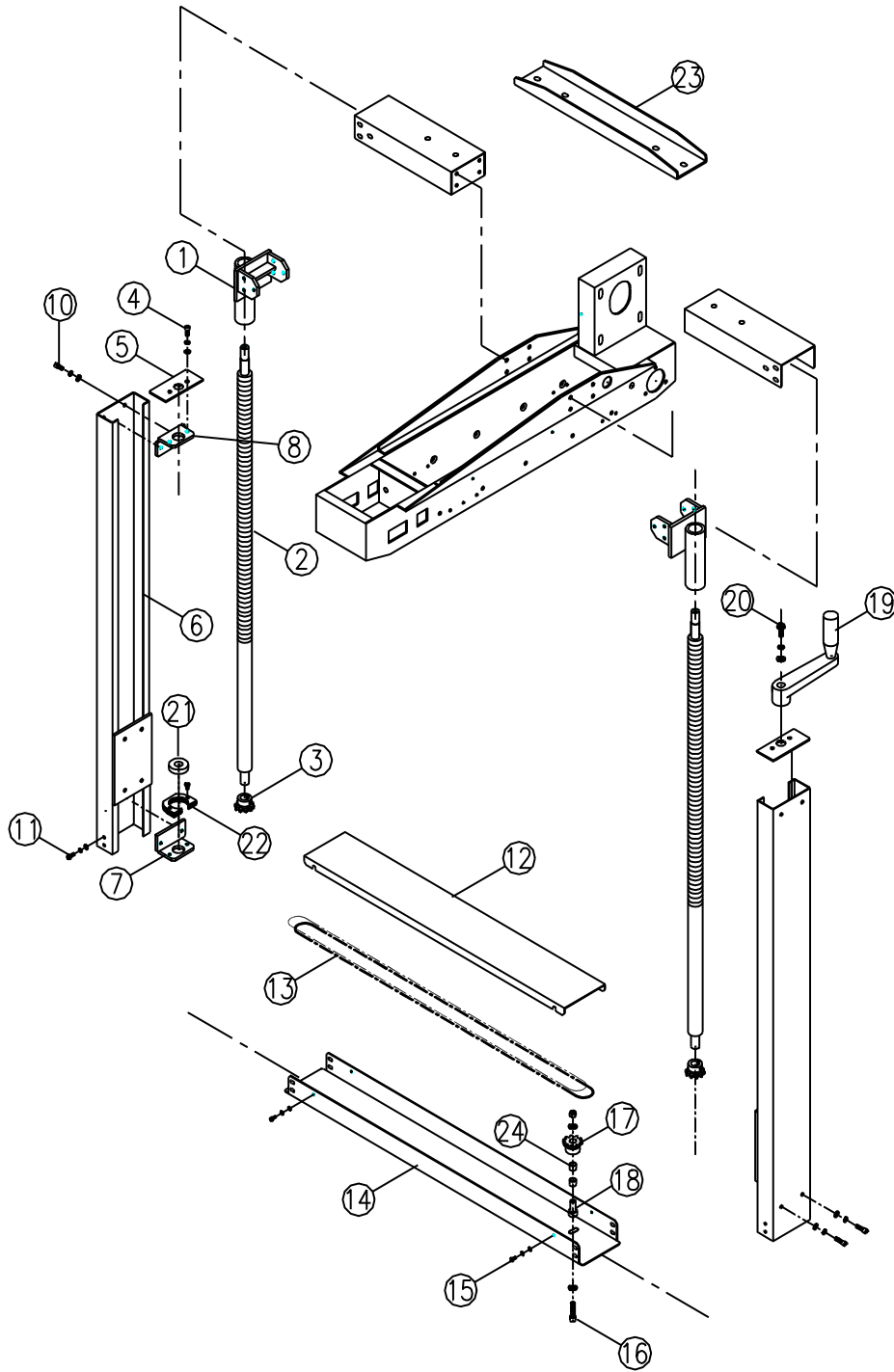

ITEM	PART NO.	DESCRIPTION	Q'TY
1	CA200900	SPINDLE SUPPORT	2
2	CA230300	HEIGHT ADJUSTMENT SPINDLE	2
3	CA200800	CHAIN WHEEL	2
4	10100612	SCREW M6 x 12L & S.W & W	4
5	CA20040A	COVER PLATE	2
6	CA23010A	COLUMN	2
7	CA200300	SET PLATE	2
8	CA200200	SET PLATE	2
9			
10	10100612	SCREW M6 x 12L & S.W & W	8
11	10100612	SCREW M6 x 12L & S.W & W	8
12	CA230500	CHAIN PLATE	1
13	3240S359	CHAIN	1
14	CA230400	CHAIN COVER	1
15	10190410	SCREW M4 x 10L & S.W & W	4
16	10100635	SCREW M6 x 35L & S.W & NUT	1
17	CA201600	CHAIN WHEEL	1
18	CA201700	CHAIN WHEEL SHAFT	1
19	CA201500	HANDLE CRANK ARM	1
20	10170816	SCREW M8 x 16L & S.W & W	1
21	30302020	BEARING 6202ZZ	2
22	CA304500	BEARING SEAT	2
23	CA131900	BRACKET, BRIDGE CHANNEL (2")	1
	CA131910	BRACKET, BRIDGE CHANNEL (3")	1
24	CT212100	BUSH Ø10 x Ø12 x 10L	2

Lower Taping Seat

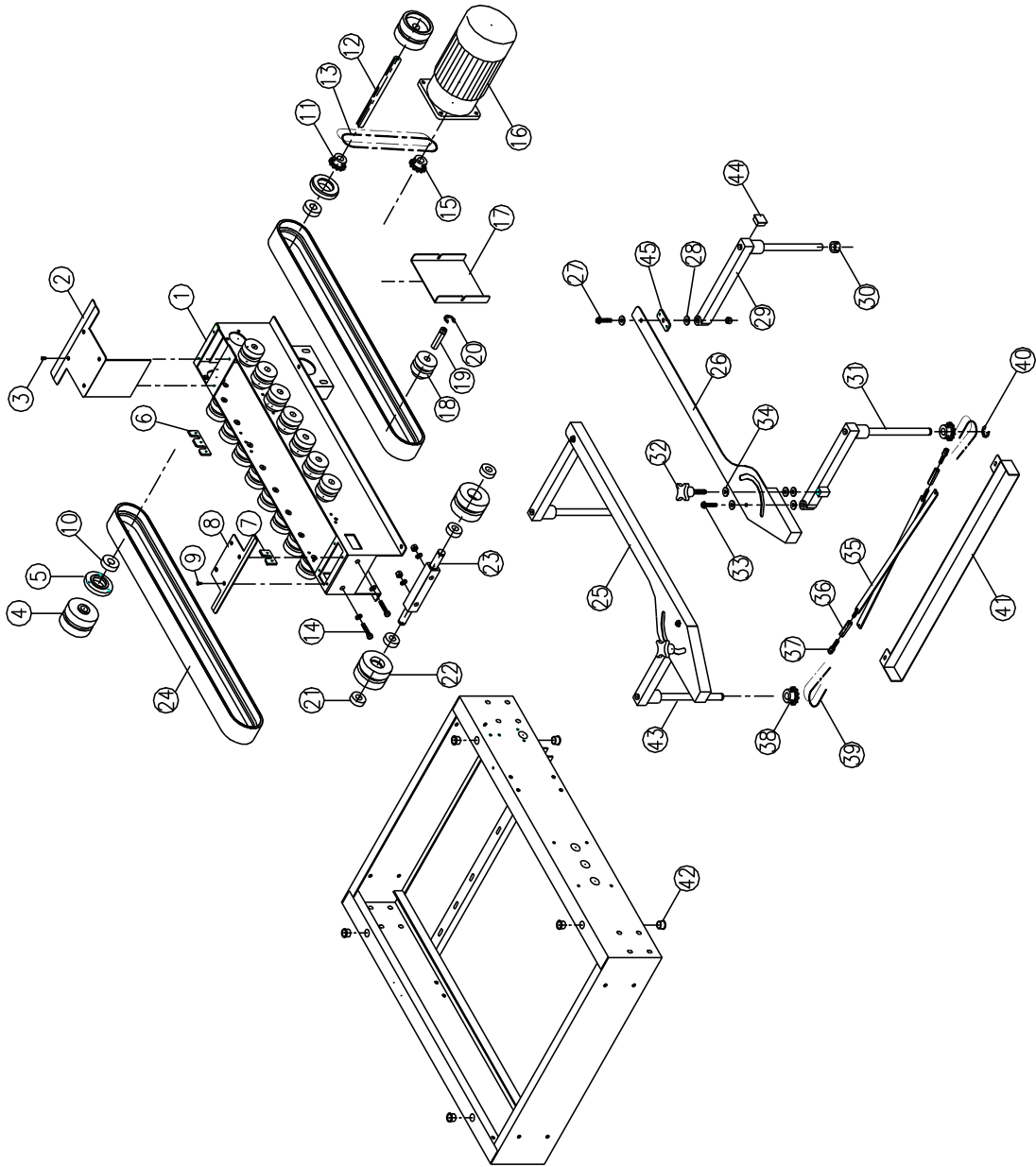

ITEM	PART NO.	DESCRIPTION	Q'TY
1	CA330200	UNDER TAPING SEAT (2")	1
	CA330210	UNDER TAPING SEAT (3")	1
2	CA332200	COVER (2")	1
	CA332210	COVER (3")	1
3	10140406	SCREW M4 x 6L	4
4	CA301900	PULLEY DRIVER	2
5	CA131000	BEARING SEAT	2
6	CA33070A	B-PLATE	2
7	CA33060A	A-PLATE	2
8	CA331700	COVER (2")	1
	CA331710	COVER (3")	1
9	10140406	SCREW M4 x 6L	4
10	30302030	BEARING 6203ZZ	2
11	CA331300	MOTOR SPROCKET WHEEL	1
12	CA331400	DRIVER SHAFT (2")	1
	CA331410	DRIVER SHAFT (3")	1
13	3240S357	CHAIN	1
14	10110870	SCREW M8 x 70L & NUT	2
15	CA331200	MOTOR SPROCKET WHEEL	1
16	745111M1	MOTOR 110V/60HZ,T18:1	1
	745122M1	MOTOR 220V/60HZ,T18:1	1
	745122M2	MOTOR 220V/50HZ,T15:1	1
	745124M2	MOTOR 240V/50HZ,T15:1	1
	745138M1	MOTOR 380V/50HZ,T15:1	1
	745140M1	MOTOR 400V/50HZ,T15:1	1
17	CA331100	MOTOR COVER	1
18	CA301300	PLASTIC PULLEY	16
19	CA301400	PULLEY SHAFT	16
20	11301200	RING STW-12	16
21	30300030	BEARING 6003ZZ	4
22	CA301100	PULLEY FOLLOWER	2

ITEM	PART NO.	DESCRIPTION	Q'TY
23	CA330800	ADJUSTABLE SHAFT (2")	1
	CA330810	ADJUSTABLE SHAFT (3")	1
24	CA331900	BELT	2
25	CA3303L0	GUIDE RAIL	1
26	CA3303R0	GUIDE RAIL	1
27	10200840	SCREW M8 x 40L & NUT	2
28	CA331500	WASHER	8
29	CA330410	GUIDE RAIL CRANK	2
30	CA331600	CRANK FITTING RING	2
31	CA3305R1	GUIDE RAIL CRANK	1
32	CA101600	HANDLDE KNOB	2
33	10200840	SCREW M8 x 40L & NUT	2
34	CA332800	HANDLDE KNOB WASHER	6
35	CA331800	CHAIN ADJUSTMENT PLATE	2
36	CA332300	CHAIN ADJUSTMENT BAR	2
37	CA332500	CHAIN ADJUSTMENT SCREW	2
38	CA200800	CHAIN WHEEL	2
39	3240S358	CHAIN	2
40	11301500	RING STW-15	2
41	CA332100	CHAIN COVER(2")	1
	CA332110	CHAIN COVER(3")	1
42	32001510	BUSH ALFF-1510	8
43	CA3305L1	GUIDE RAIL CRANK	1
44	91350001	RUBBER PLUG	4
45	CA332900	DIRECT AGAINST PLATE	2

Machine Body

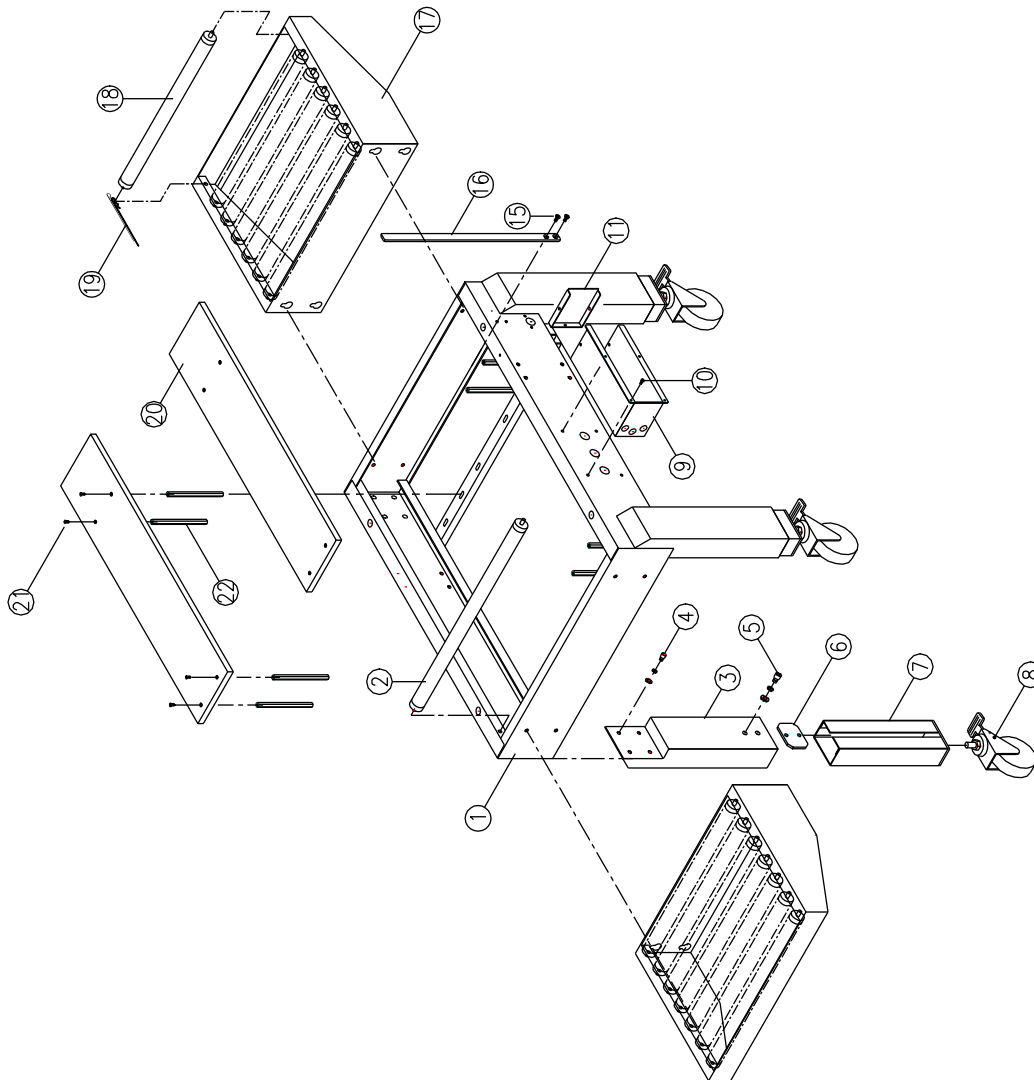

ITEM	PART NO.	DESCRIPTION	Q'TY
1	CA33010A	MACHINE FRAME	1
2	CA332000	ROLLER	1
3	CA300200	MACHINE LEG	4
4	10100816	SCREW M8 × 16L & S.W & W	16
5	10101016	SCREW M10 × 16L & S.W & W	8
6	CA30040A	CLAMP	4
7	CA30030A	ADJUSTABLE LEG	4
8	9201L501	CASTER	4
9	CA30280A	ELECTRICAL BOX	1
10	10170510	SCREW M5 × 10L	4
11	CA304300	ELECTRICAL COVER	1
12			
13			
14			
15	10140612	SCREW M6 × 12L	2
16	CA101400	FIXED SEAT	1
17	CA430100	ROLLER SEAT	2
18	CA430200	ROLLER	14
19	10750001	PIN	7
20	CA331000 CA331010	MACHINE FRAME COVER (2") MACHINE FRAME COVER (3")	2 2
21	10140410	SCREW M4 × 10L	8
22	CA330900	SHAFT	8

Tape Head — Refer to Tape Head User Guide.

Refer to the parts illustrations and listings in the Tape Head User Guide provided with the tape head for identification and part numbers of tape head parts.

Warranty Statement

TB-2/3 Industrial Case Taping System

Warranty Statement

Eastey Enterprises warrants that all of the products it ships will be in good working order and free from defects in material and workmanship and will conform to the published specifications for that product.

Warranty Period

Drive motor(s): 1 year
Gear reducer: 1 year

Tape head: 1 year (Except for moving parts which are subject to normal wear, tear and replacement which are warranted to be free from defects in material and workmanship.)

All other parts: 1 year (Except for moving parts which are subject to normal wear, tear and replacement which are warranted to be free from defects in material and workmanship.)

Taping Quality

Taping quality achieved in a given application is dependent on the installation, the material handling, and the maintenance provided. Eastey makes no warranty that the print quality achieved in an application will be the same as that achieved on a test piece in our demo facility.

Shipping Policy

Customer pays all incoming shipping. If the item is defective and under warranty, Eastey pays return shipping charges for least costly method. If expedited shipping is desired, customer must furnish his shipping account and shipping fees will be charged to that account.

Warranty Verification

If you conclude that a product may be defective and may be covered by warranty, obtain a Return Material Authorization number by calling our technical support number (toll free at 1-800-835-9344, or 763-428-4846 or Fax: 763-795-8867) or e-mail: info@eastey.com, and return the defective item to Eastey. Eastey will analyze the product and, if found to be defective, we will, at our option, replace or repair the item. If the item is found to not be eligible for warranty, you will be notified and may decide on disposition. Defective products will be replaced or repaired as promptly as possible.

Warranty Eligibility

The warranty provided by Eastey Enterprises, Inc. is only to the original buyer.

Limited Warranty

THE ABOVE WARRANTY IS EXCLUSIVE AND IN LIEU OF ALL OTHER WARRANTIES, WHETHER EXPRESSED OR IMPLIED, INCLUDING THE IMPLIED WARRANTIES OF MERCHANTABILITY, FITNESS FOR A PARTICULAR PURPOSE AND NONINFRINGEMENT.

Disclaimer of Damages

REGARDLESS OF WHETHER ANY REMEDY SET FORTH HEREIN FAILS OF ITS ESSENTIAL PURPOSE, IN NO EVENT WILL EASTEY ENTERPRISES, INC. BE LIABLE FOR ANY SPECIAL, CONSEQUENTIAL, INDIRECT OR SIMILAR DAMAGES, INCLUDING LOST PROFIT OR LOST OPPORTUNITIES OF ANY TYPE ARISING OUT OF THE USE OR INABILITY TO USE THESE PRODUCTS EVEN IF EASTEY ENTERPRISES, INC. HAS BEEN ADVISED OF THE POSSIBILITY OF SUCH DAMAGES.

Customer Support

Eastey Technical Service

For help setting up or operating the TB-2/3 Case Taper, please contact Eastey Technical Service at one of the numbers listed below.

Toll-Free Phone	800-835-9344
Phone	763-428-4846
Fax	763-795-8867
E-mail	info@eastey.com
Web	www.eastey.com

Thanks again for your purchase of Eastey products. We are pleased to be a part of your packaging needs.



EASTEY®