



Shrink Sleeve Label Applicator Model Number LX-100

User Guide



AFM

Shrink Sleeve Label Applicator Model Number LX-100

User Guide

Revised 4/20/2018

P/N 4510004 Rev Beta

Copyright and Trademarks

Copyright ©2018 American Film and Manufacturing.
All rights reserved. All trademarks and brand names
are the property of their respective owners.

AFM
7041 Boone Avenue North
Brooklyn Park, MN 55428

Phone: (714) 974-9008; Fax (763) 795-8867

www.afmsleeves.com

Contents:

- Safety 8**
- Introduction..... 11**
 - System Components 11
 - System Dimensions 12
 - System Specifications 13
 - Description and Main components 14
- Installation and Setup..... 16**
 - Location Requirements 17
 - Data Cable and Power Connections 18
- Operation..... 19**
 - Before Running Product 19
 - Location of Switches 19
 - Loading a Film Roll 20
 - Threading Film 21
 - Sub-Assemblies 22
 - Changing/Installing/Adjusting Mandrels 24
 - Conveyor 31
 - Motion Detector Sensor (product trigger) 31
 - Adjustment locations 34
 - Typical setup 35
- Testing 36**
- Touch Panel Screens (H.M.I.) 43**
 - Screens 43
 - Screen 10 43
 - Screen 15 43
 - Screen 12 44
 - Screen 30 44
 - Screen 13 45
 - Screen 14 46
 - Screen 31 46
 - Screen 33 47
 - Screen 11 47
- Maintenance..... 48**
 - Changing Cutter Blades 48
 - LX-100 50
 - Weekly 50
 - Every three weeks 50
 - Every six months 50
 - Annually 51
 - Every two to three years 51
 - Unwind System 52
 - Daily 52

Every six months.....	52
Every two years.....	52
Frequency	52
Troubleshooting	53
General	53
Specific problems while running machine	55
Motion Detector	58
Motion Detector Sensor Details.....	58
Motion Detector Sensor Setup	59
Print Reading Sensor details.....	60
Print Reading Sensor setup	61
Operation Appendix	62
Exploded Assembly Diagrams	69
Schematic Diagrams.....	75
Optional	81
Parts List.....	85
Warranty Statement AFM Products	91
Customer Support	95

Safety

The AFM Shrink Sleeve Label Applying Machine is easy to install, operate and maintain. Please follow these safety steps to insure smooth and safe operation:

All operators should study this manual thoroughly before operating the machine.

- Always follow GMP (Good Manufacturing Practices) when operating this machinery.
- The machine is heavy. While unpacking and setting up the unit, always take care to use proper lifting techniques. Avoid over-reaching and leaning over while handling the machine and accessories. Use more than one person to lift and move the labeling system (four is recommended), or use a minimum 1.25-ton forklift.

CAUTION

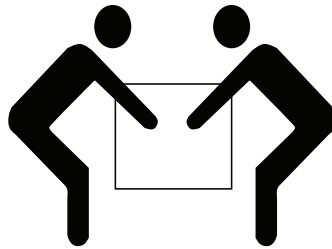

TEAM LIFT

- Wear safety shoes and work gloves when moving the machine.
- Beware of uneven spots on the factory floor, as the machine could tip over.
- Make sure the electrical power source is properly wired and grounded. The power source should comply with all safety regulations and codes applicable to the installation location.
- Before attempting any service or repair, make sure that the power is turned off and power cable is disconnected from the power source.
- Before connecting the air supply, make sure that the pressure gauge is closed and that the pressure indicator reads zero.
- The equipment generates heat, so make sure the area is properly ventilated.
- Do not place any body parts or tools into a running machine!
- Turn off and unplug the machine while servicing and performing maintenance procedures.

- Be sure to use correct lockout/tagout procedures when performing maintenance and repairs on this machinery.
- The blades used on this machine are extremely sharp. Handle with extreme care. Preferably use cut-resistant gloves when replacing blades.
- Never remove any GROUND connection from this equipment. Failure to follow this directive could result in damage to the equipment, fire, serious personal injury, or death.
- Keep water away from the electrical enclosure (at the rear of the machine), the control panel, and all other electrical components.
- This machine is protected by hardware MCR and E-STOP and door safety interlocks. Under no circumstances should these be disabled.
- The LX-100 incorporates line-control interlocks which may allow it to start automatically, without warning.
- Take care when lifting heavy rolls of labels. If lifting from ground-level be sure to lift with the large muscles of your legs.
- Always consult with AFM before making any modifications to the electrical circuitry or PLC program.
- Always replace fuses and other protective circuit devices with those of the appropriate current rating.
- When working with glass containers always wear safety glasses with side-shields.
- Some shrink label materials contain toxic chemicals. Be sure to store and dispose of properly.
- E-STOP and safety doors should never be used to stop the machine; E-STOPS are for EMERGENCY ONLY; safety doors should only be opened once the machine has come to a stop. Failure to follow these directives could result in damage to the servo drives and VFDs.



Ensure that machines are grounded.



Crush hazard. Do not place hands or other objects on moving mechanism. Shut down machine before doing any maintenance or troubleshooting.



Cut hazard. Do not place hands or other objects on moving mechanism. Shut down machine before doing any maintenance or troubleshooting.



Electrical hazard. No user serviceable parts. Keep out of power supply.



Keep equipment dry and indoors.

Introduction

The LX-100 Shrink Sleeve Label and Tamper-Evident band applicator is designed for middle, full-body, and full-body and cap applications. It is designed for low-to-moderate production rates for industries such as food and beverage, pharmaceutical, nutraceutical, health and beauty, and other manufactured goods. It can be used for horizontal or vertical perforation applications.

System Components

- LX-100
- HMI
- Unwind Station
- Take-up Reel

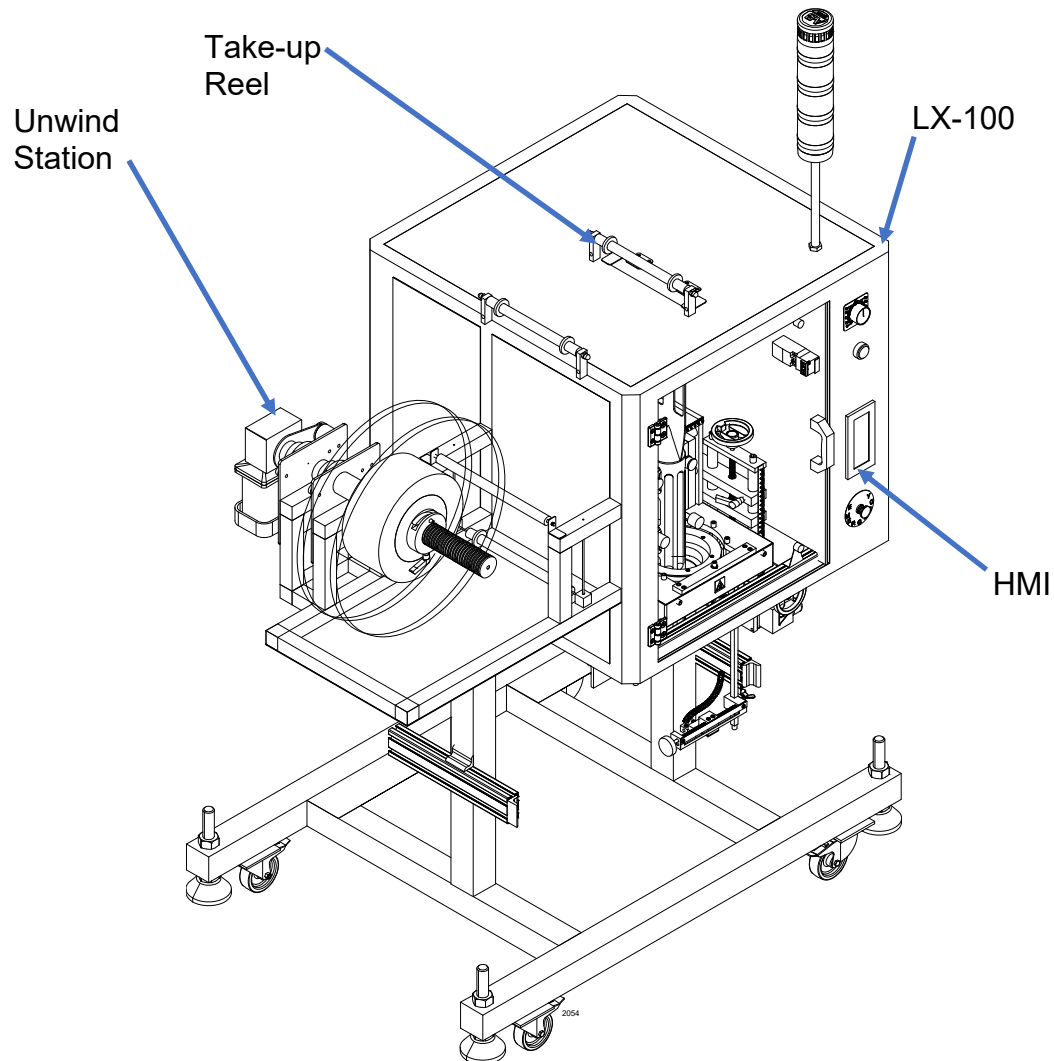

System Dimensions

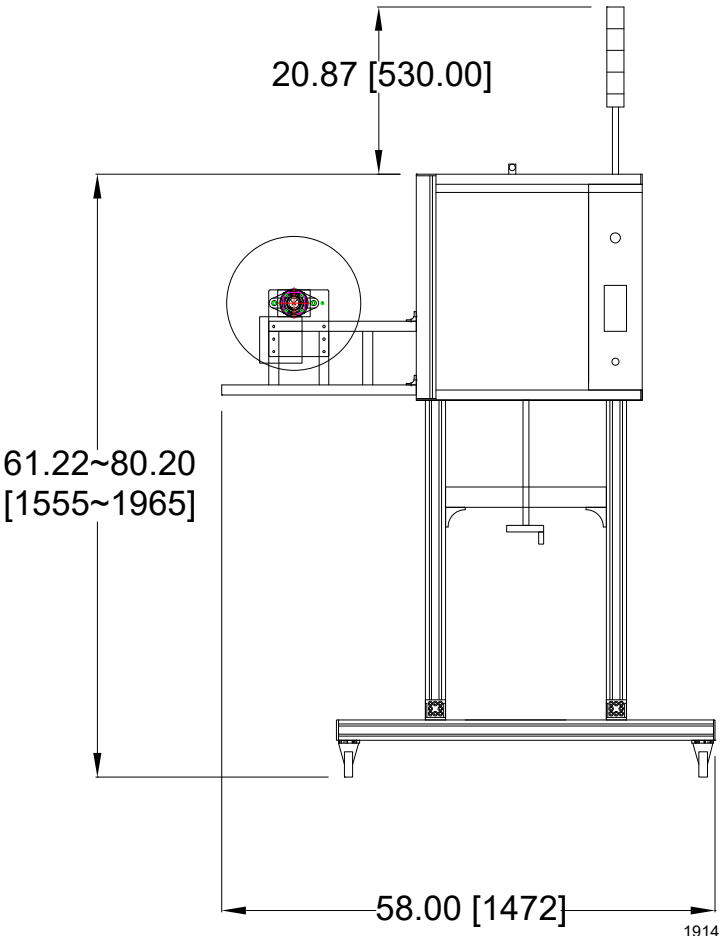
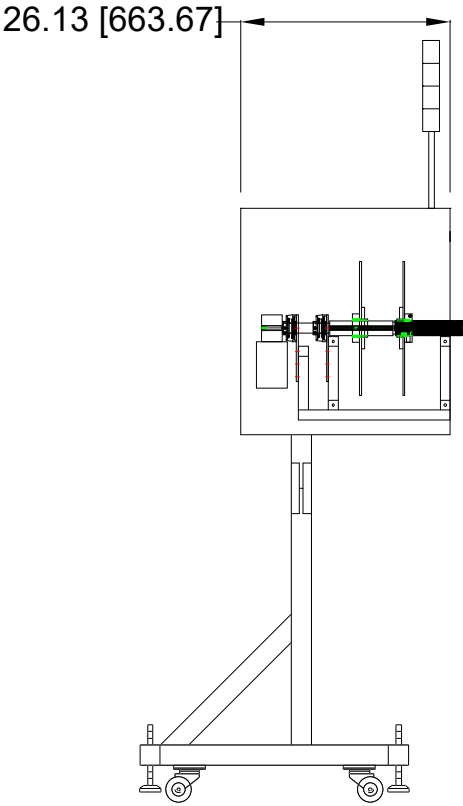
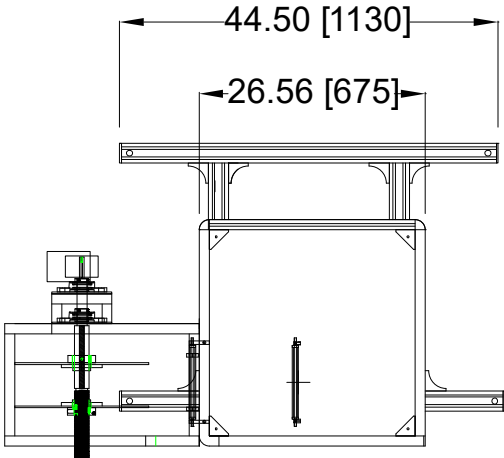

System Specifications

Power: A.C. 3-Phase, 220 Volt, 50/60Hz

Motor: 150W X 2, 60W X 1, 750W X 2

Film Width: 40-170mm

Length: 30-200mm

Thickness: 0.035-0.07mm

Applied Material: OPS, PET, PVC

Speed: 100 BPM Max. (PET Film, cut length 100mm)

Speed will vary with the shape and types of items, thickness, and length of shrinkable film. Correct speed can be determined by actual running conditions.

Reference formula: objects diameter + 1.5~2mm x 1.57.

Description and Main Components

The AFM LX-100 shrink sleeve labeler feeds tubular plastic film (OPS, PET, PETE, PVC, PLA, etc.), opens it around a Mandrel (former or “bullet”), cuts the film to the required length and places it on the containers passing under the mandrel. The film cut-length can either be triggered by an eye-mark on the film (*print-registration* mode, using the transition between opaque and clear on the printing of the film) or can be based upon a fixed number of pulses generated by the encoder of the Film Feed Drive motor (NO PRINT mode, selectable from the SETTING screen).

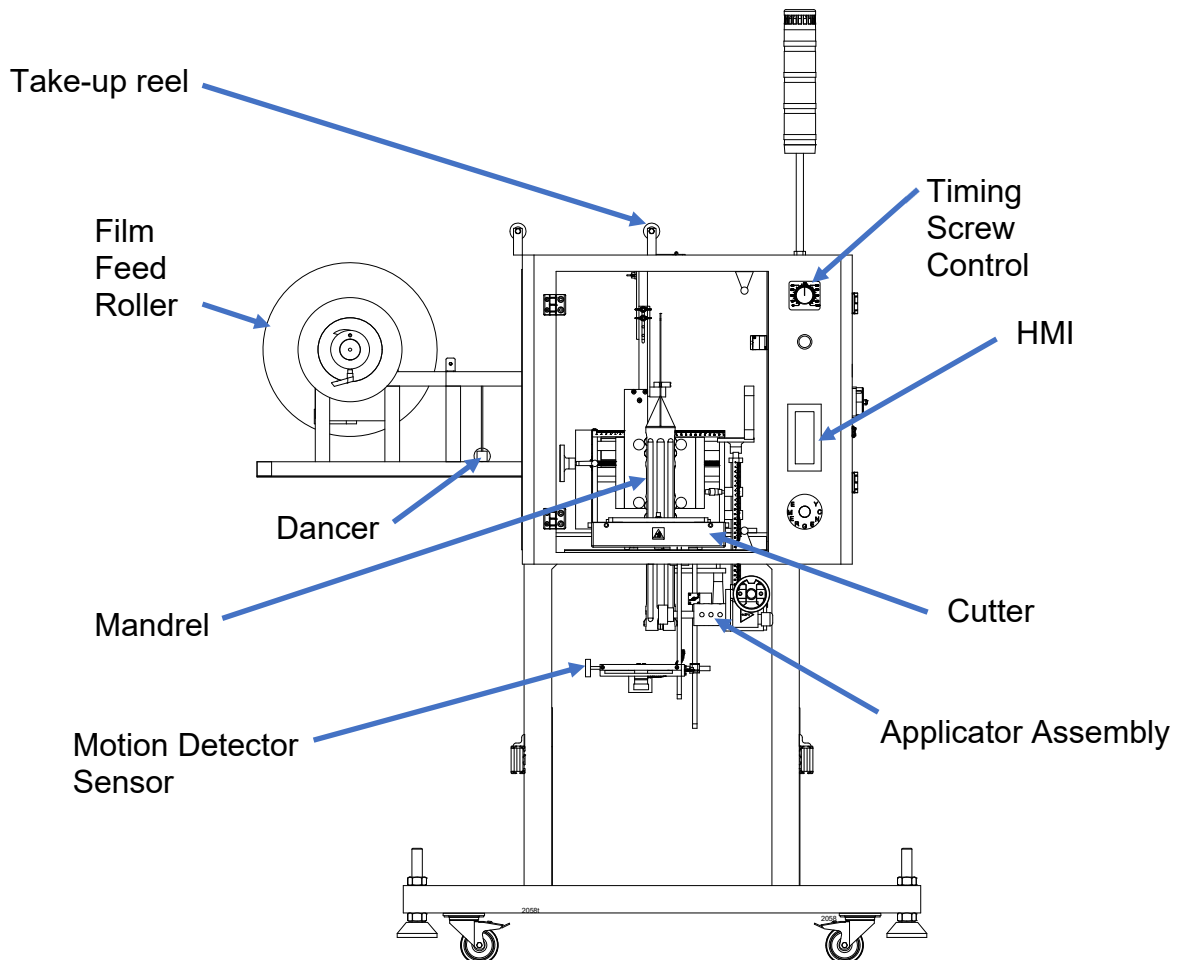

With the addition of the perforator option, each label can be perforated on the machine to offer tamper-evidence, or to facilitate removal by the consumer.

The Film Feed Roller feeds the film by one label cut length each cycle, and the Wheels on the Applicator assembly shoot each cut label onto the container; the cut > film-feed cycle is triggered by the approach of the container, as detected by the Motion Detector Sensor Eye. The label at the base of the Mandrel is first cut; then, as the feed cycle begins, it is pushed down into the path of the (continuously rotating) Applicator Wheels, which shoots the label onto the container.

The Take-up Reel system on the LX-100 is designed to maintain back-tension in the film, to maintain correct registration for the Cutter, and to give a cut with minimal tails and burrs.

The Obstruction (Jam) Sensor monitors each label as it passes under the Mandrel and stops the machine automatically if a label fails to make it down below the Mandrel, or if a label becomes stuck at the base of the Mandrel.

Conveyor Side Belts and Brush-down units are two optional extras which can be used, depending upon the application. The Side-belts are generally not used in cases where the bottom of the label is to come down all the way to conveyor level; in cases where the label is designed to stop part of the way down the container, or is a shoulder label, the Side-belts can be used to support the bottom of the label as it is applied to the container.

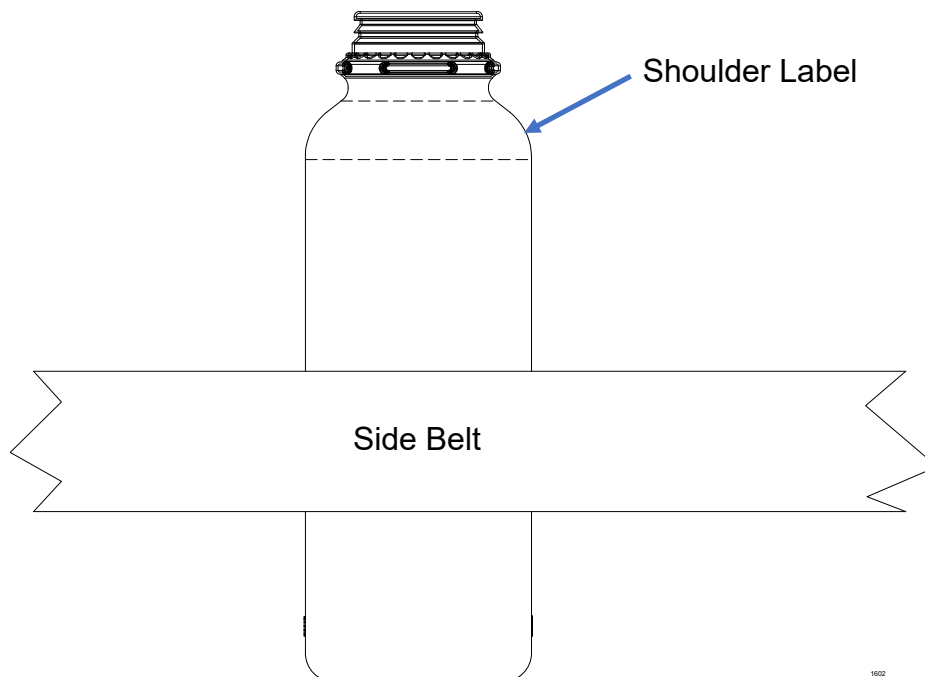

Brush-down may be necessary when the labels fail to consistently go down to the desired height on the container (for example, when the containers coming into the machine are wet).

The LX-100 has its own film unwind device. Since the LX-100 is a shrink sleeve labeler, a Heater Tunnel (steam, convection or infrared) must be used also.

Installation and Setup

The LX-100 will have been pre-tested with your product prior to shipment.

Included in box:

- LX-100
- Unwind

Optional:

- Conveyor
- Horizontal perforator
- Vertical perforator
- Heat tunnel
- Timing screw / Timing Belts
- Side Belts
- Accumulator
- Brush-down
- TTO Printer
- Encoder

Please see your dealer for any optional equipment purchases.

Location Requirements

- Place machine in the location where it can be easily accessed from all sides.
- Ensure that unit is level. Adjust levelling using the levelling feet.
- Align the mandrel with the center line of the conveyor.
- Adjust the height of the machine by turning the adjustable feet until the space (A) from the top of the container to the bottom of the mandrel (B) is approximately half the length of a label. When this has been completed, tighten the adjustable feet. Most of the adjustment to set the height of the mandrel, relative to the top of the container, is accomplished with the crank on the side of the labeler. The leveling mounts should just be used to put the LX100 at a height where both the shortest and tallest bottles can be accommodated. Level the Machine and Conveyor.
- Secure the conveyor to the machine using a brace.
- After verifying that the supply voltage matches the voltage shown on the name-plate and on the electrical schematics, connect the three-phase power.
- Install the timing screw assembly so that the screw ends at least 12 inches upstream of the Mandrel.

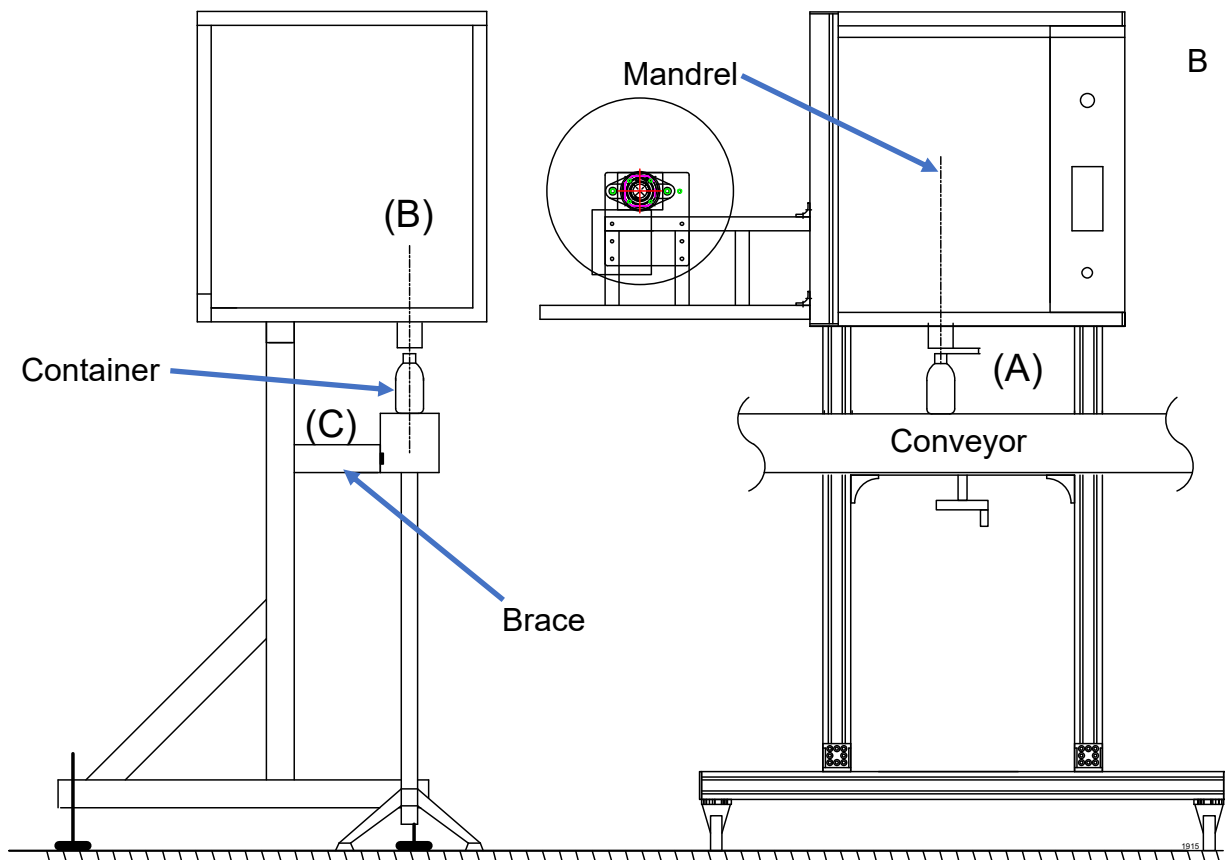

Data Cable and Power Connections

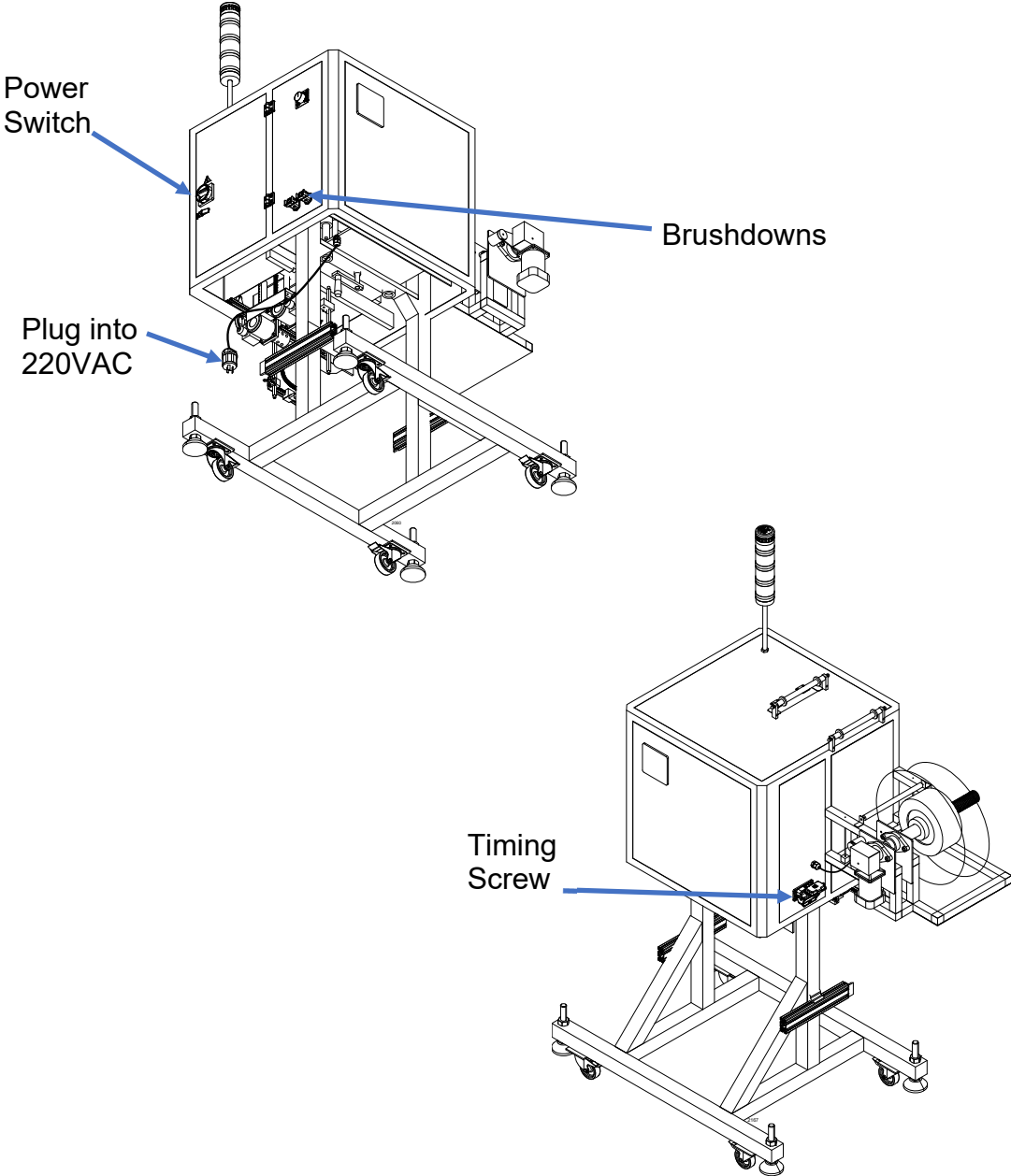

Connect HMI, Touchscreen, and Conveyor before plugging into power. Make sure power switch is set to “off” before plugging in. Do not “hot plug” any of the assemblies.

Brushdown hookups are located on the outfeed side, and any Feed (Timing) Screw hookups should be located on the infeed side.

Operation

Before Running Product

Before running product, be sure to check the following:

1. Container Conveyor Guide-widths and Timing Screw position should correspond to the width of the container and centering of the Mandrel on the conveyor.
2. Check that the Mandrel is installed securely.
3. Use MANUAL MODE to verify the correct cut and, when applicable, perforation position.
4. Use a container to make sure that the Brush-down units are set correctly (if applicable).
5. Verify that your Heater Tunnel is set up correctly.
6. Verify that the Motion Detector Sensor Eye is at the correct height – usually to detect the leading edge of the cap of the product.

Location of Switches

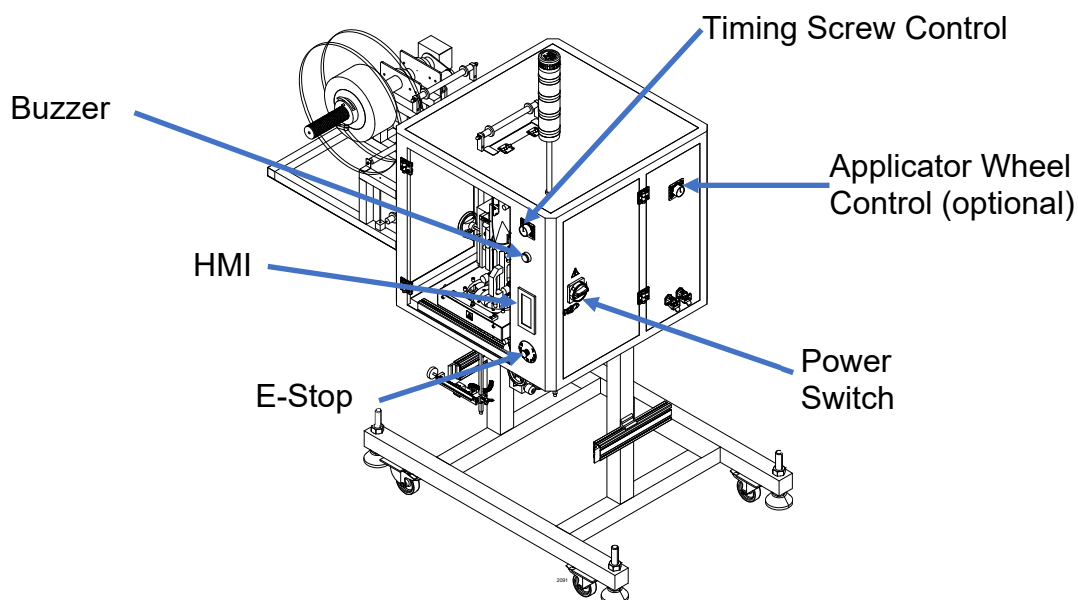

Loading a Film Roll

The film roll cannot be larger than the Film Reel cover. Prepare the unroll unit by doing the following:

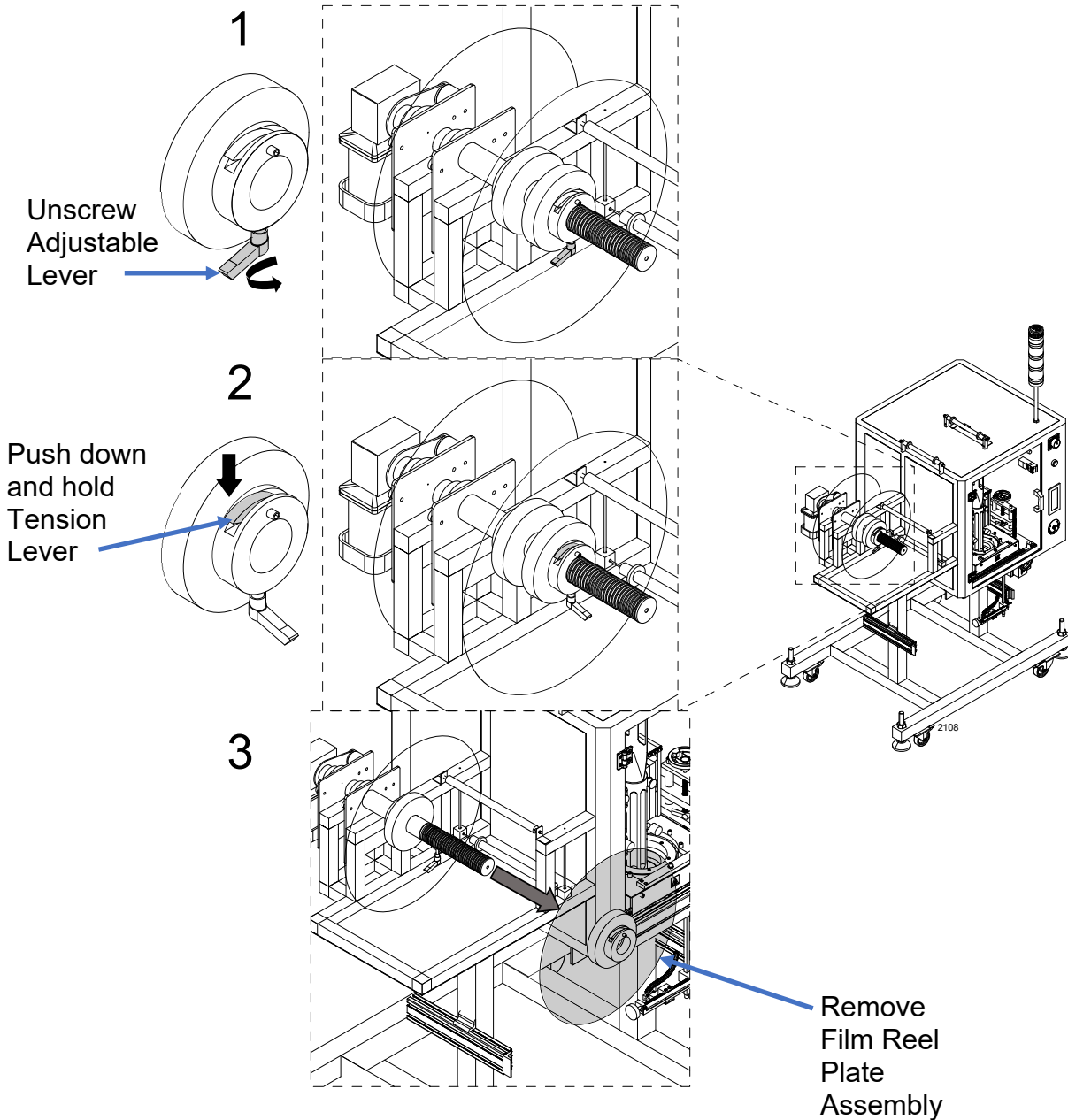

Place Film onto Reel Assembly, replace assembly doing steps in reverse order. Center the film to the tooling or Mandrel.

Threading Film

Thread the film as seen in the following illustration.

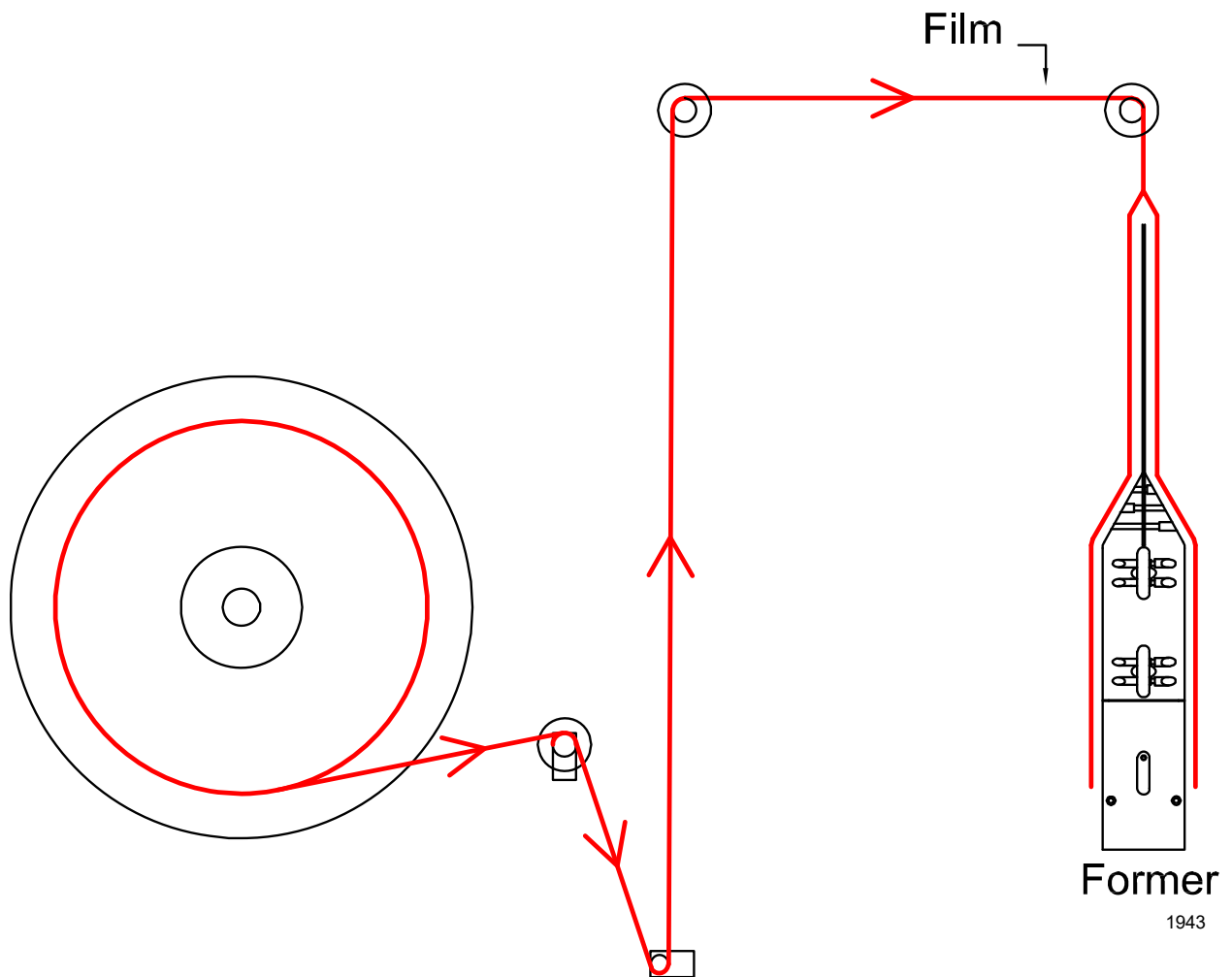

Ensure that sleeves are facing the correct orientation coming out of the roll.

Sub-Assemblies

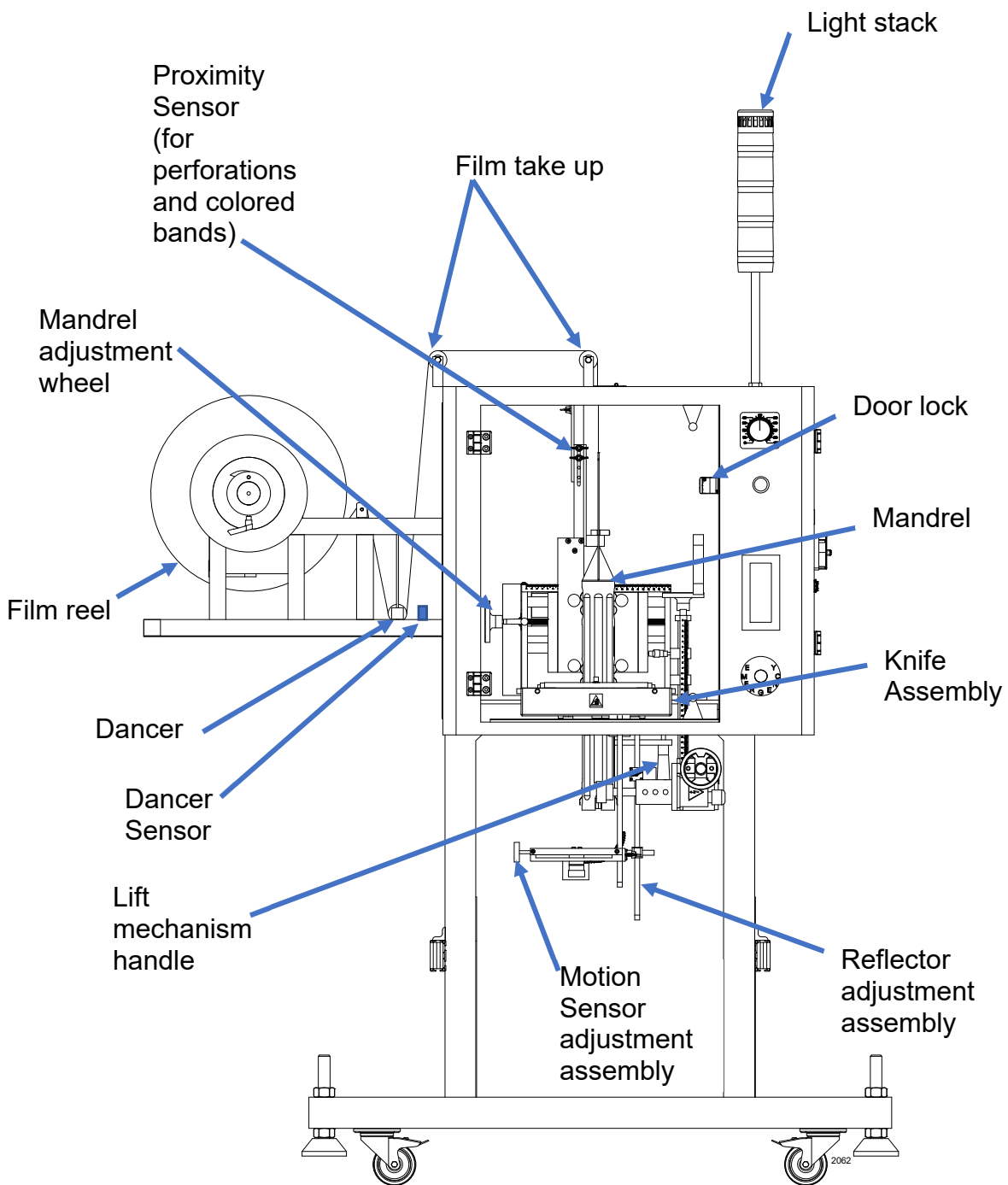

Steps to RUN:

Note:

- If mandrels are large diameter, adjustments of the Right-hand or Left-hand Bearing Guide may be required. Secure using Phillips Head screws.

Mandrel in:

Load Film based on the application. Follow the steps from pages 20-21 Unwind and Mandrel.

Manual-use the up-down buttons if no material is present to advance the web.

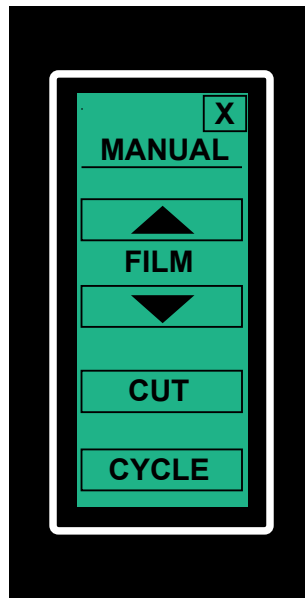

Watch the top and bottom, and the side-to-side. Adjust while pressing button. Hold the Mandrel and adjust the Timing Screw Control.

Changing/Installing/Adjusting Mandrels

It is good practice to adjust the mandrel if it is already installed before putting film on it. Turn on the power at the power supply for Unroll unit. The LX-100 should already be unrolled per previous (See “Threading Film”).

To install the Mandrel, open the front door and loosen the set screw holding the tension steel and rubber wheel assembly. Turn the Adjustment Wheel counter-clockwise to loosen the Tension Wheels in preparation of setting/installing the Mandrel.

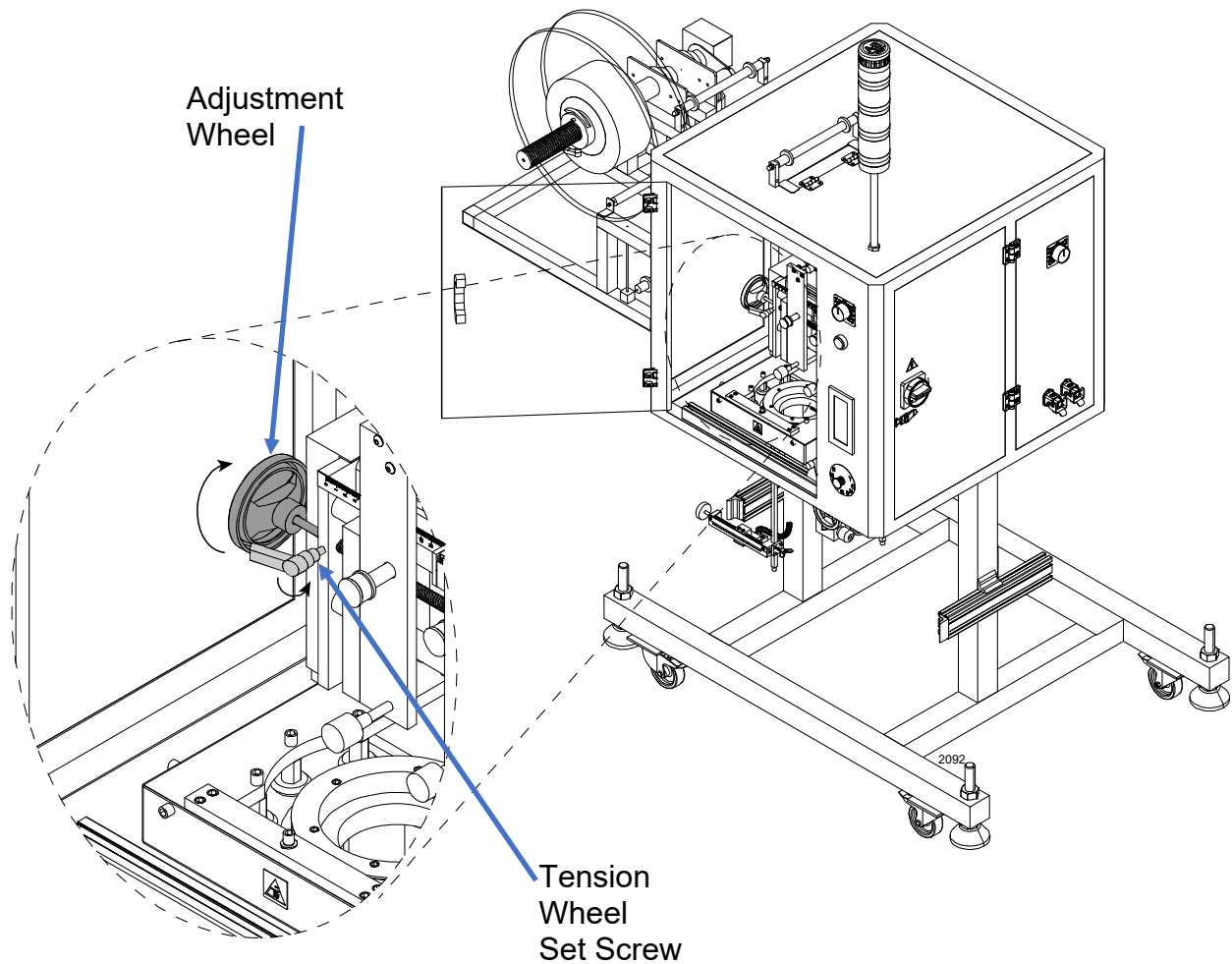

Carefully pass the Mandrel down through the center of the Cutter unit oriented with the fin pointed towards the rear of the unit through the Print-Reading Sensor. The cutouts are for the groove in the Print-Reading Sensor, which “looks” for the clear spot (gap) in-between the colored labels in the film. The Sensor is adjustable. Make sure that the Mandrel is situated with the Mandrel’s bearings near the wheels (see following for setup).

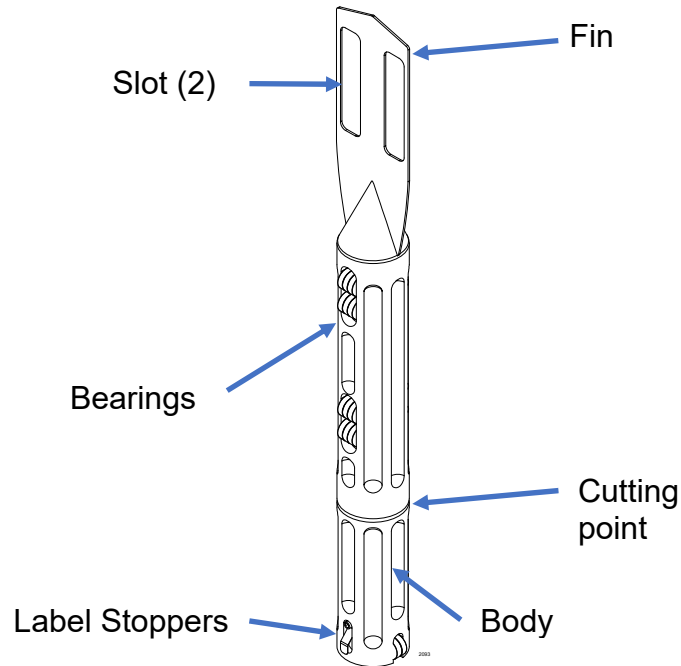

Carefully feed the Mandrel through the door opening into the Cutter Assembly (longer Mandrels may be fed through the top). Open Applicator Wheels and allow pass-through.

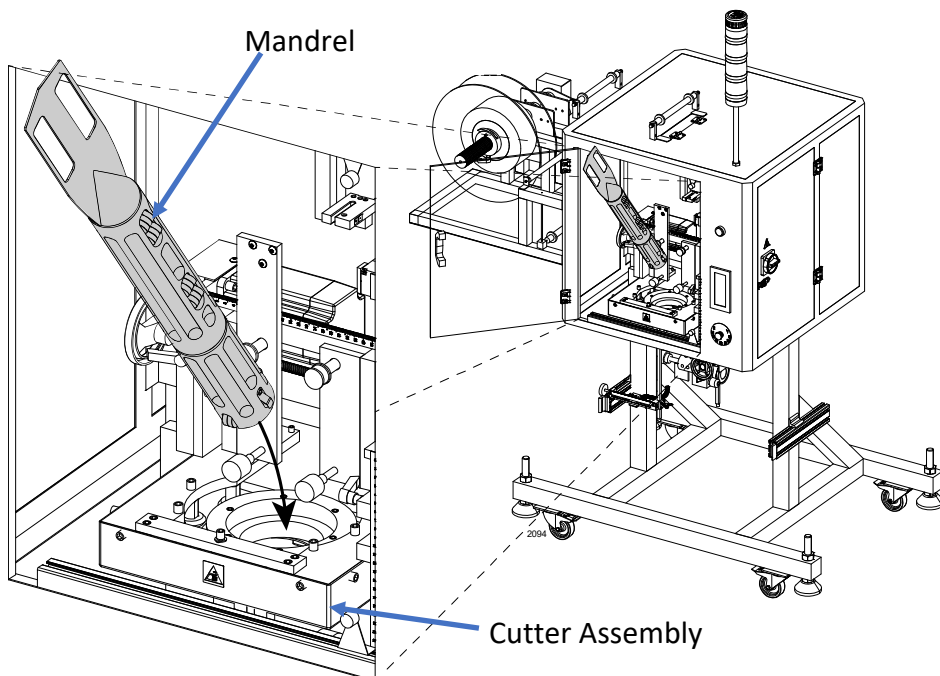

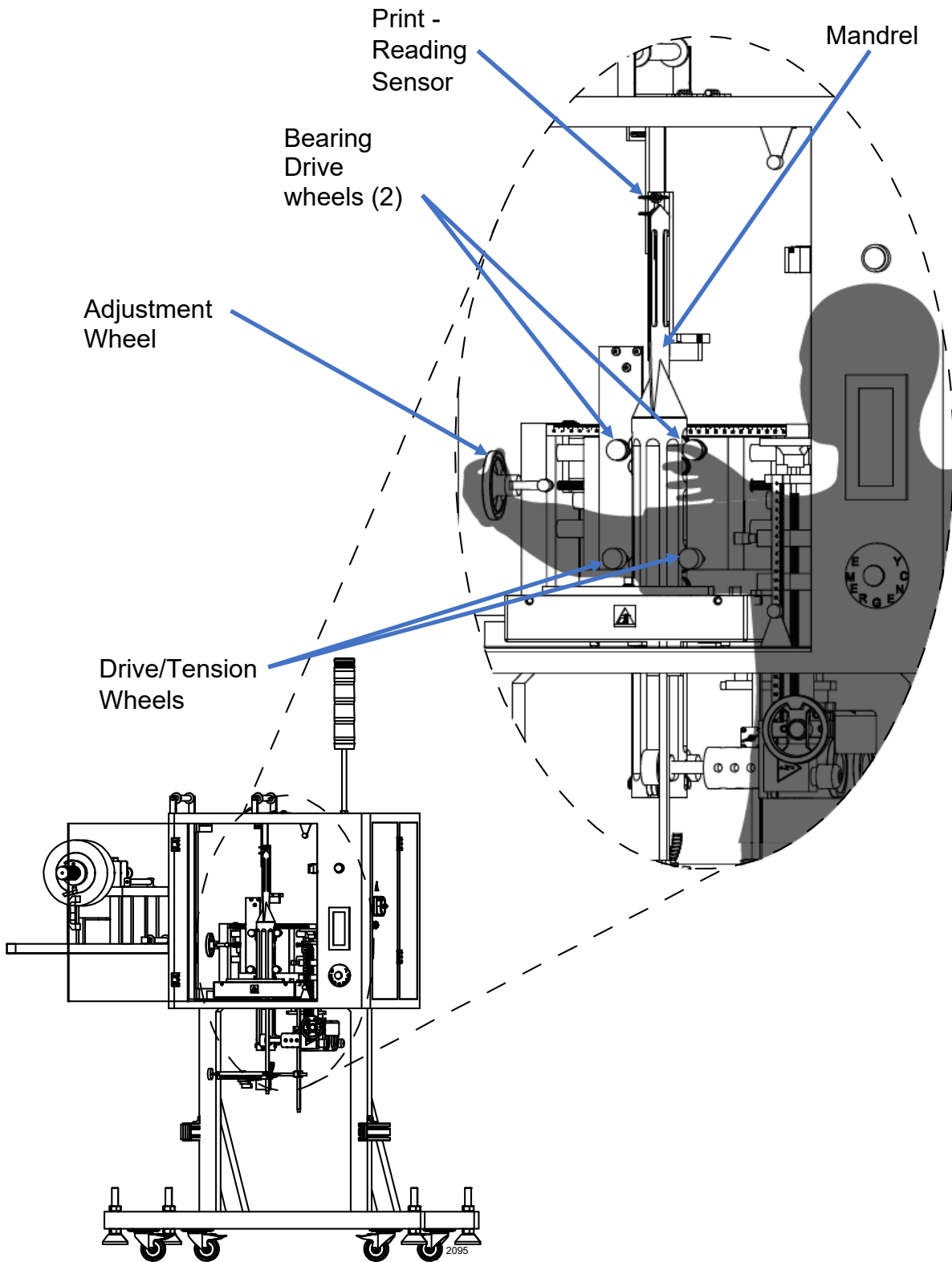

Grasp the mandrel and hold it in place while adjusting the steel wheels. Using the adjusting knob, tighten until the steel wheels touch the bearings in the front and rear of the mandrel. Line up if needed.

Tighten the Support Rollers (bearings) so that they locate the Mandrel in the center of the Cutter unit (you may have to momentarily loosen the Film Feed Rollers to do this) turning the dials counter-clockwise. The Bearing Drive wheels should be loose enough to rotate, but not so loose that they can be spun.

Next, adjust the Applicator Wheels using the adjustment dial on the far right-hand side. Rotate the dial until it clicks, and rubber wheels are snug to the Mandrel.

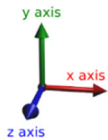
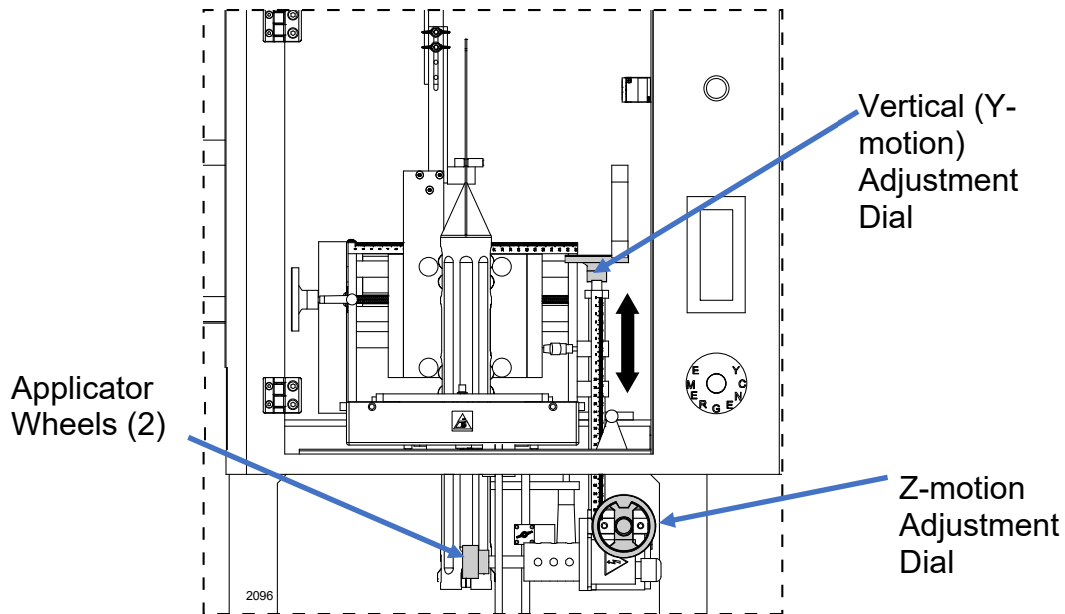

Side Applicator Wheels should be tight, leaving a slight gap for film. Tighten Bearing Drive Wheels, then back off leaving a gap for the film.

Open the end of the film so it is not stuck together.

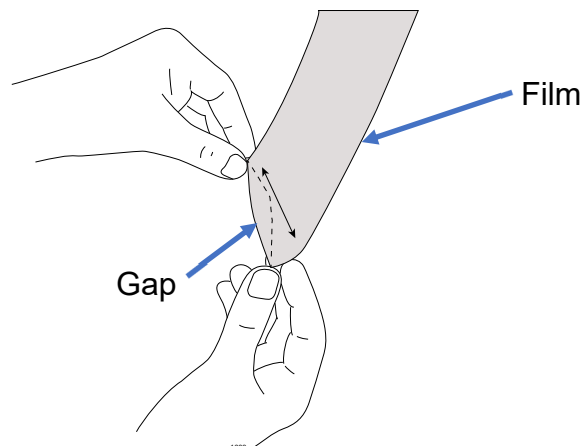

After film has been loaded, cut length and cut time need to be set up.

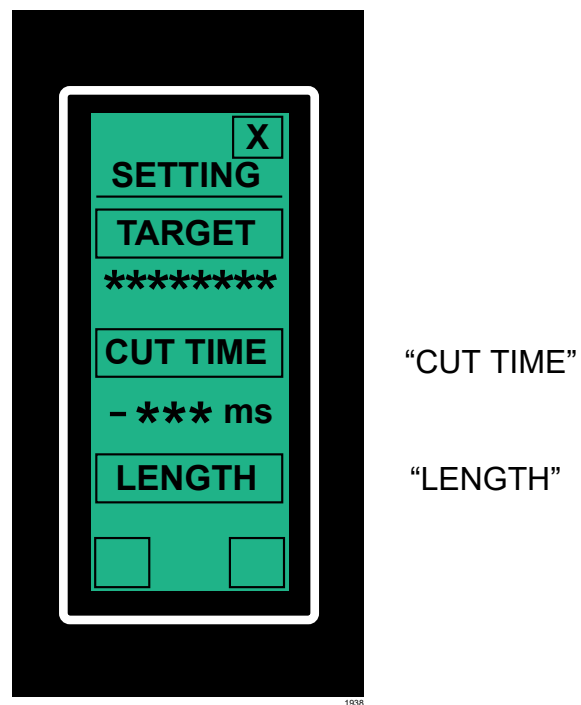
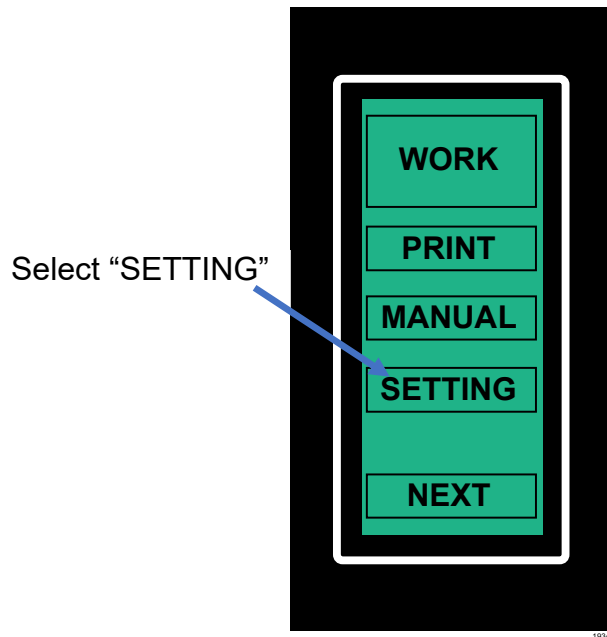

Pull the film, and slip it over the end of the Mandrel's fin. Pull film past the Print-Reading Sensor so that the amber LED goes out. Continue pulling over the cone-shaped tip, manipulating it as you go. Push the film down onto the Mandrel until it reaches the second set of rubber wheels.

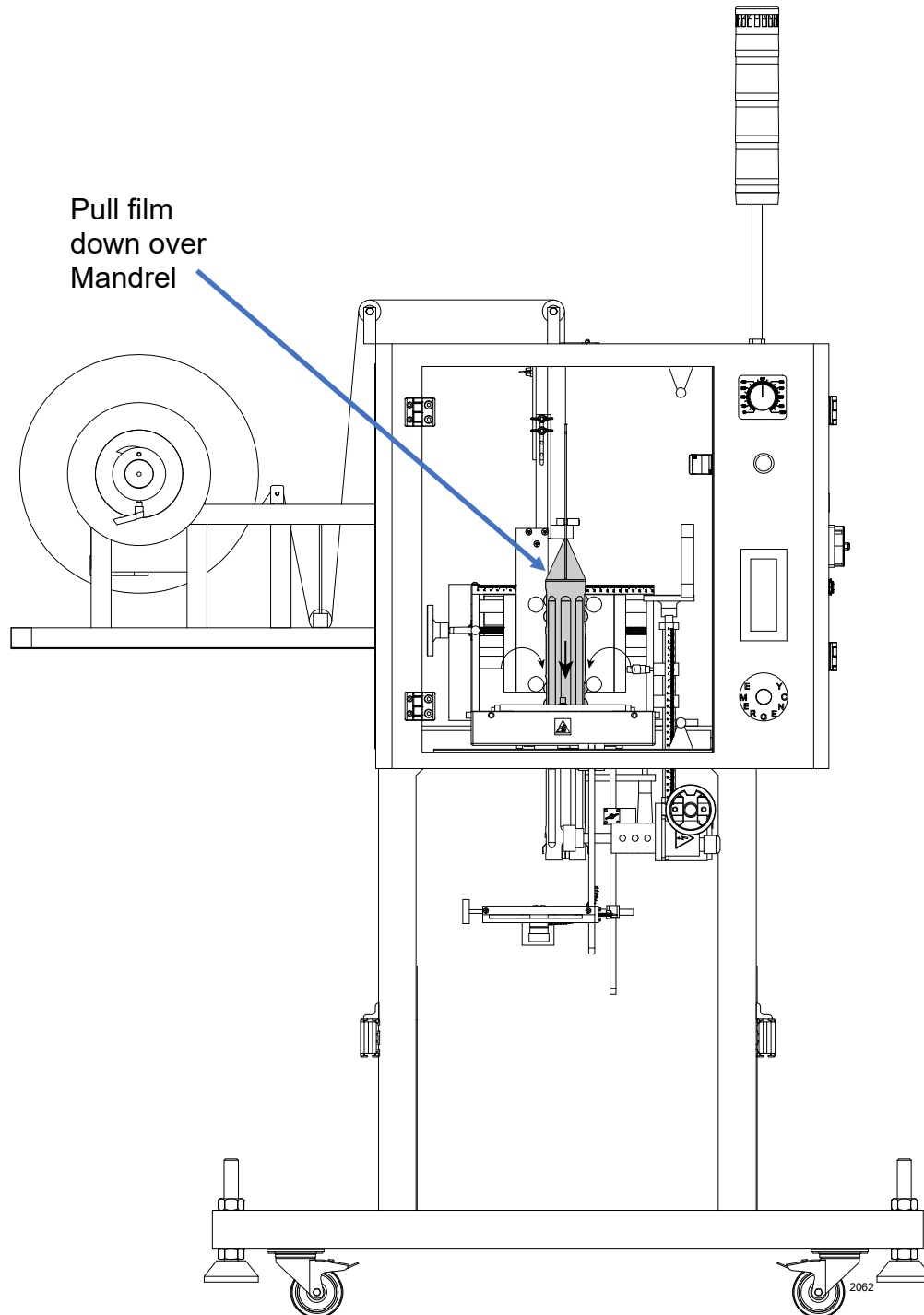

Turn on power on the right side of the cabinet.
Close the door to engage the safety interlock switch.

Go to the HMI screen and press “**MANUAL**” tab, press the “**FILM**” ▼ button.

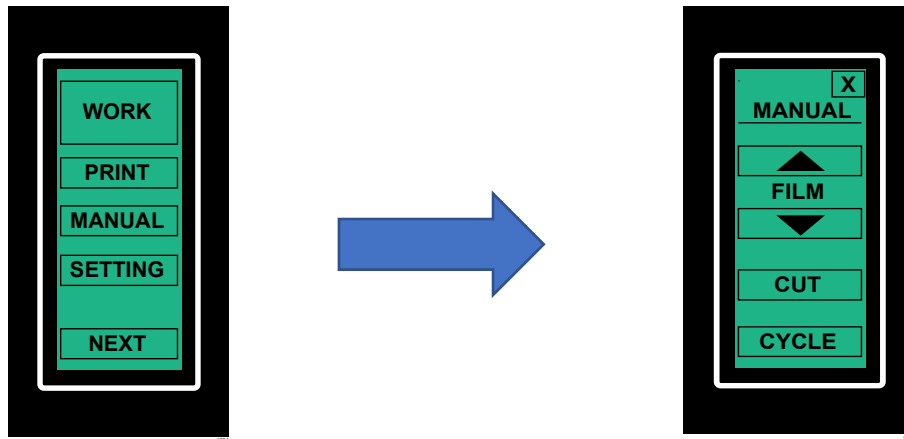

Film will self-align on the mandrel. Drive film down past cutting point of Mandrel. Run the film until it is not “wrinkled”.

Press “**CUT**”, The film is cut. Check to see if it is cutting between cutting point of Mandrel. If Cutter is performing correctly, re-tighten the set screws for both sets of wheels.

The Film Feed Roller adjustment is located on the front right-hand side inside the door of the LX-100. The illustration shows the area of location. The wheels of the Film Feed “Spitter” are vertically adjustable, and can be loosened or tightened on the Mandrel using the Tightening Adjustment wheel. Horizontal movement is pre-set, and is not adjustable.

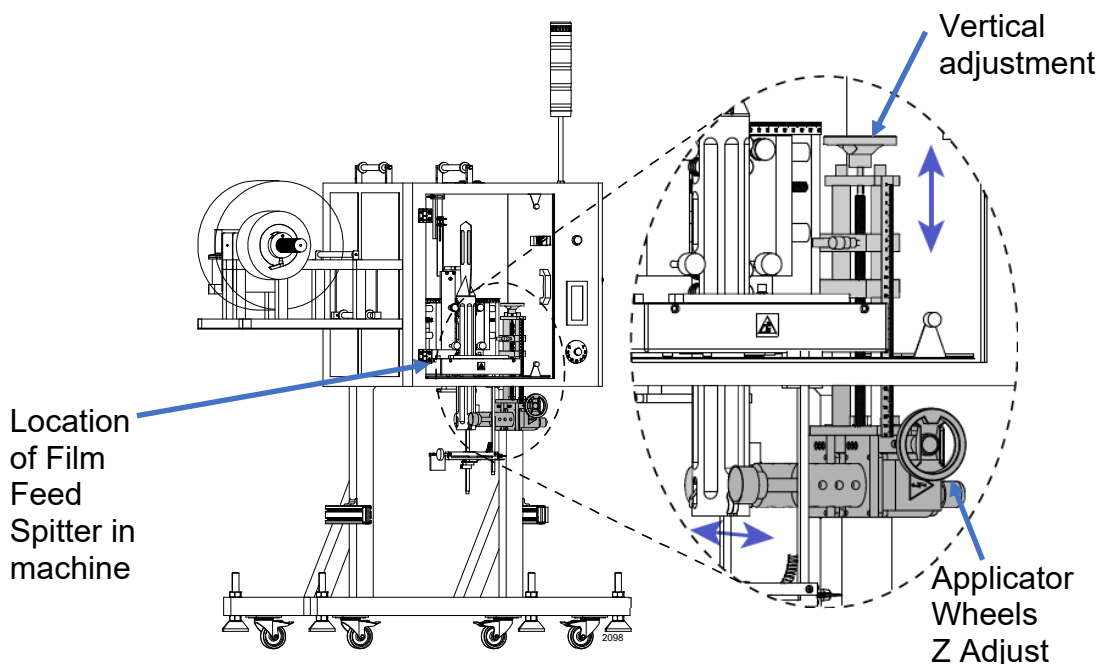

If wheels are too loose or too tight, there may be “burnout” marks left on the film and rollers. Ensure that adjustments are done accordingly.

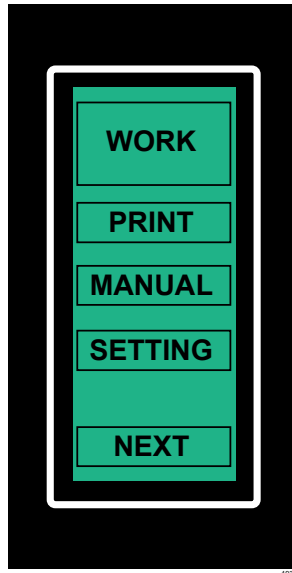

Press “**CYCLE**” once. The machine will buzz three times, and the operator will hear the rollers move. Press “**CYCLE**” a few more times and check the film when it comes out for smoothness, consistency, and correct cut.

The LX is preliminarily set up, and is ready to accommodate the Conveyor.

Conveyor

The LX-100 is fed by conveyor. Using the Handle on the underside (see page 44), the cabinet can be raised and lowered to accommodate the introduction of the conveyor. Likewise, the Conveyor can be adjusted for height, and levelled. Raise the LX-100 cabinet, and move the Conveyor underneath it. Check to see that the Conveyor is in line with the cabinet. Place a product on the conveyor and under the cabinet and adjust the height of the LX until the Mandrel is approximately 1-1/2 inches above the product (depending on product).

Set speed of Conveyor and Timing Screw. Run test samples to ensure product is centered to the Mandrel.

Motion Detector Sensor (product trigger)

Adjust the Motion Detector Sensor on the LX-100 to vary the timing of the label application. Using the knob on the front Motion Detector Sensor, the user can retard (to the right) and advance (to the left) the product speed accordingly. The Obstruction (Application Fail) Sensor is for jams, or “pile-up” of film.

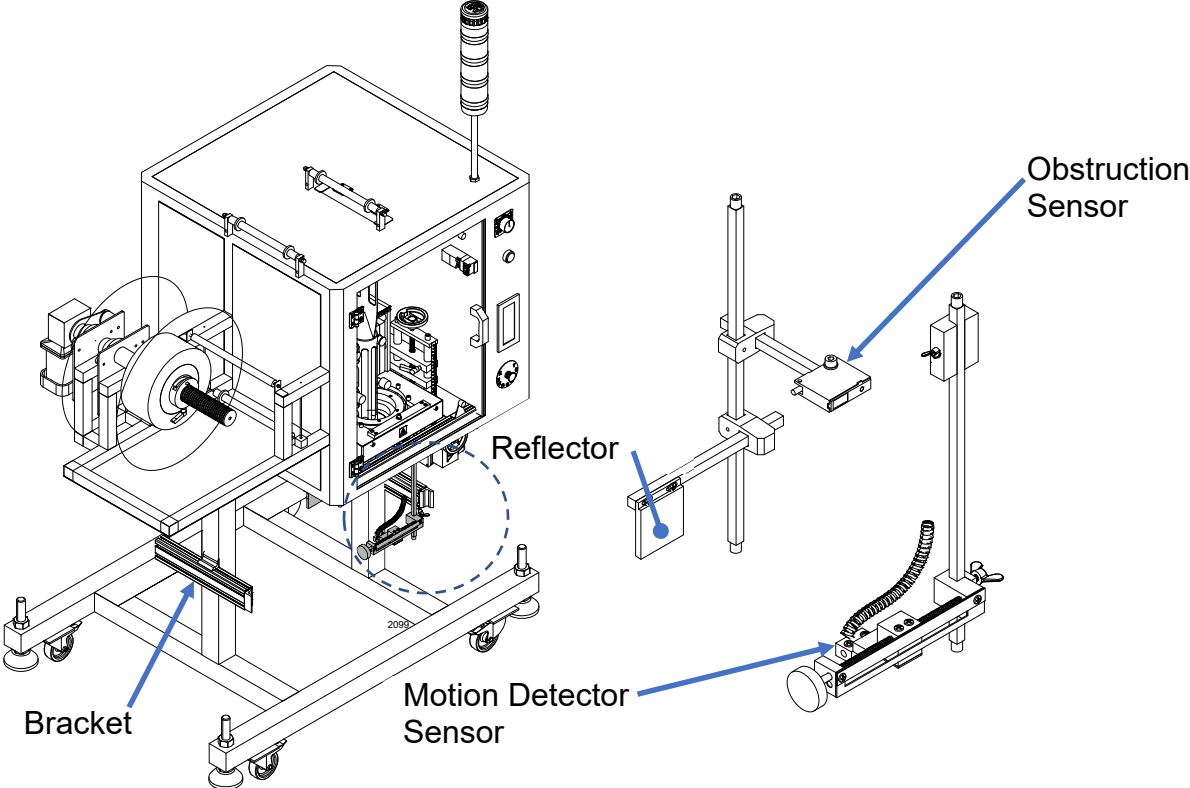

The item being sleeved breaks the sensor as it goes by on the conveyor. The Sensor determines whether the item is “there” and if so, get sleeved.

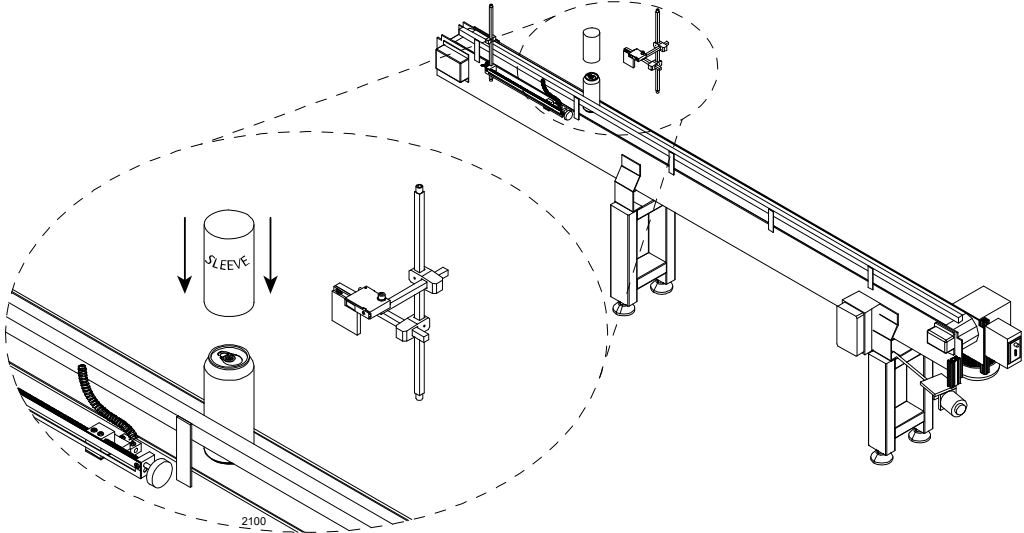

Adjust Sensor to get best application.

The LX-100 is lowered or raised to accommodate the conveyor using the Crank Handle underneath the unit.

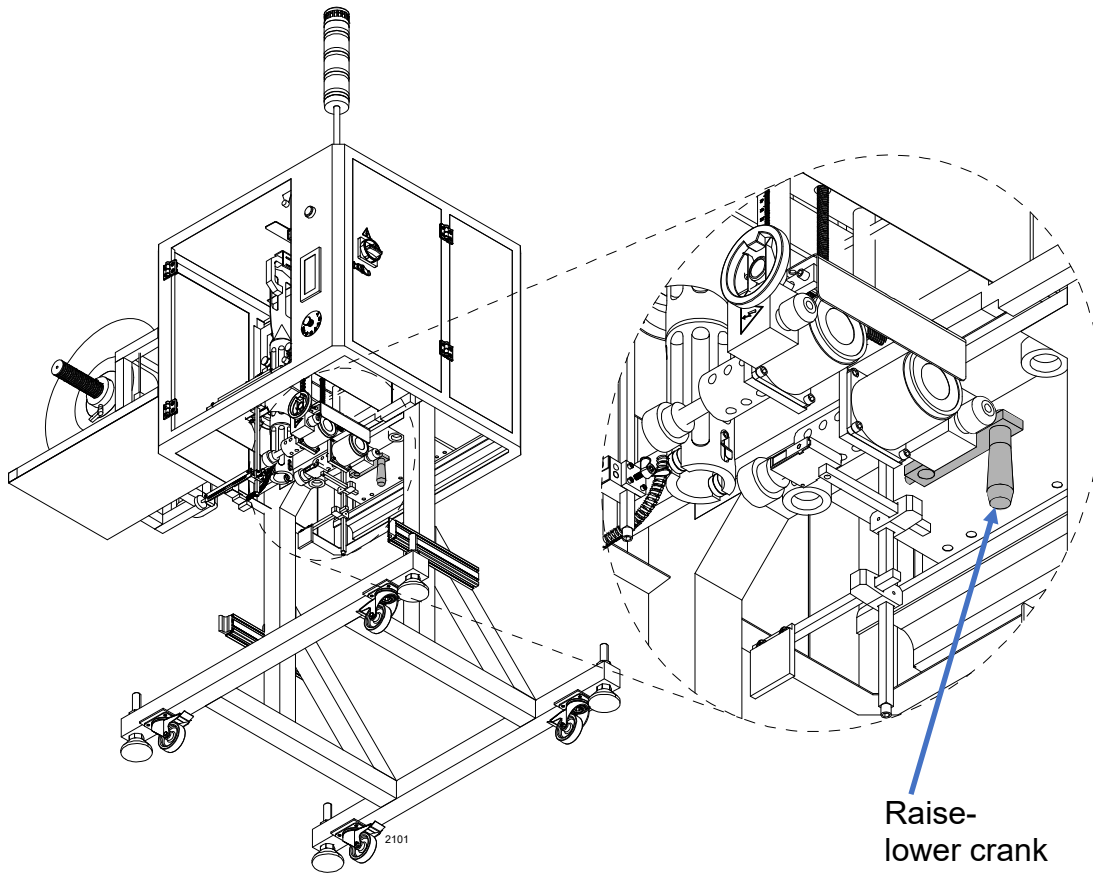

Adjustment locations

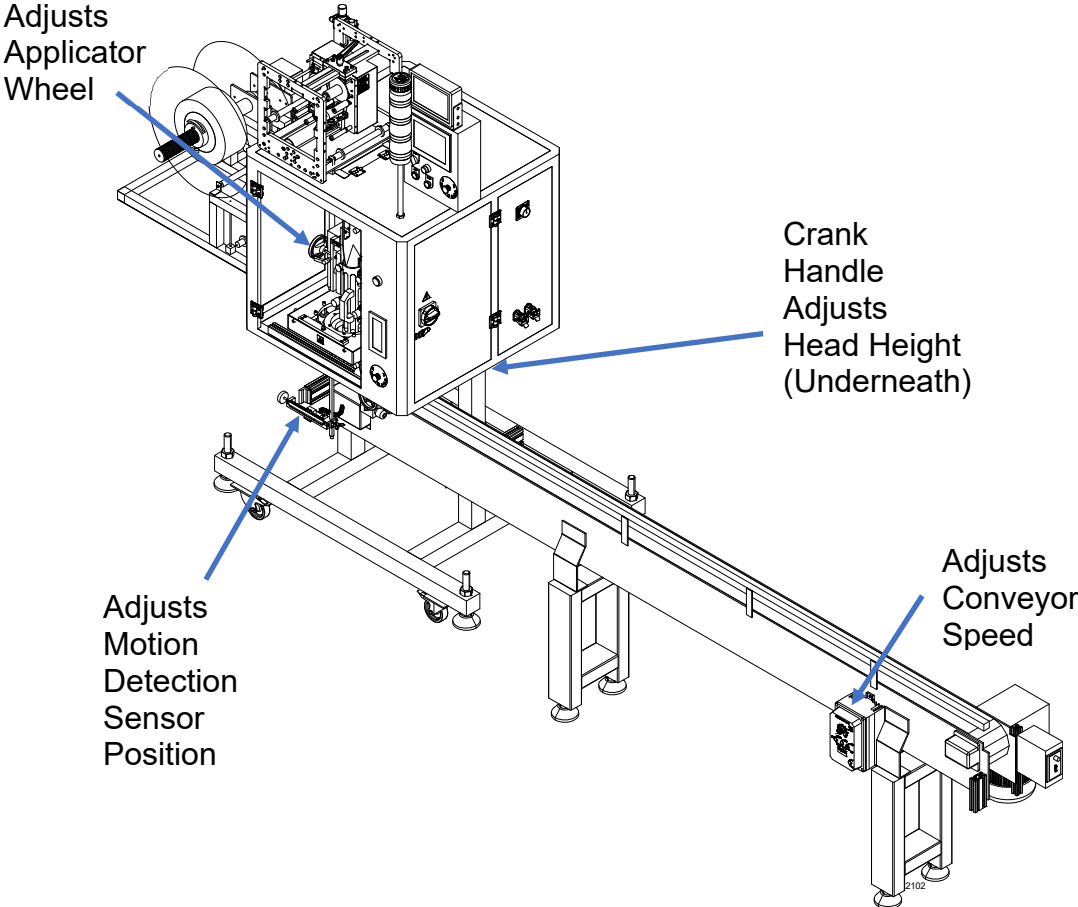

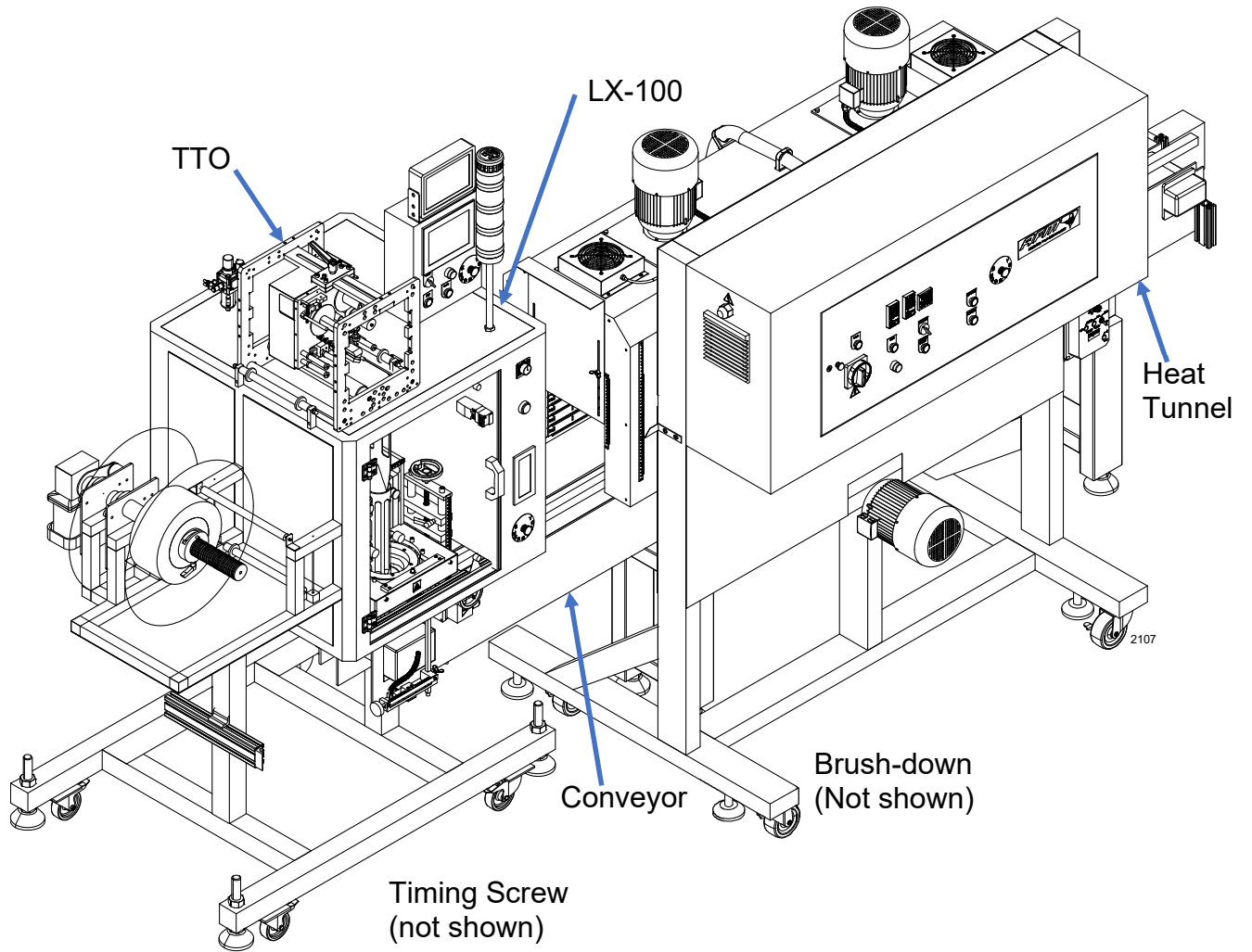

Typical setup

Testing

Without using the reading print sensor

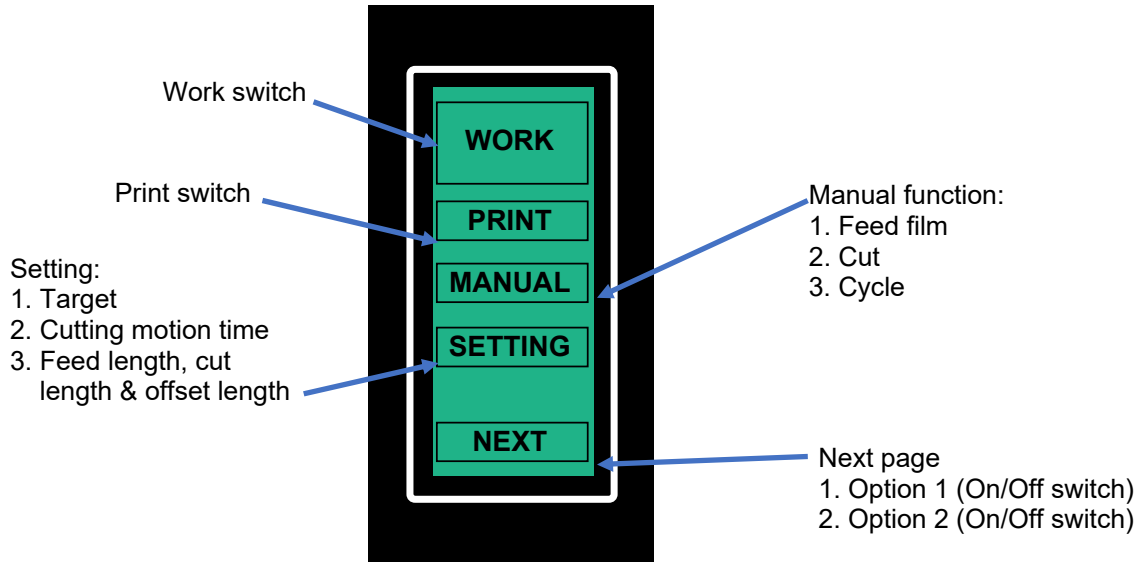

Press "SETTING"

1. Press "LENGTH" to set up the cut length (press the "star" to access the keyboard).

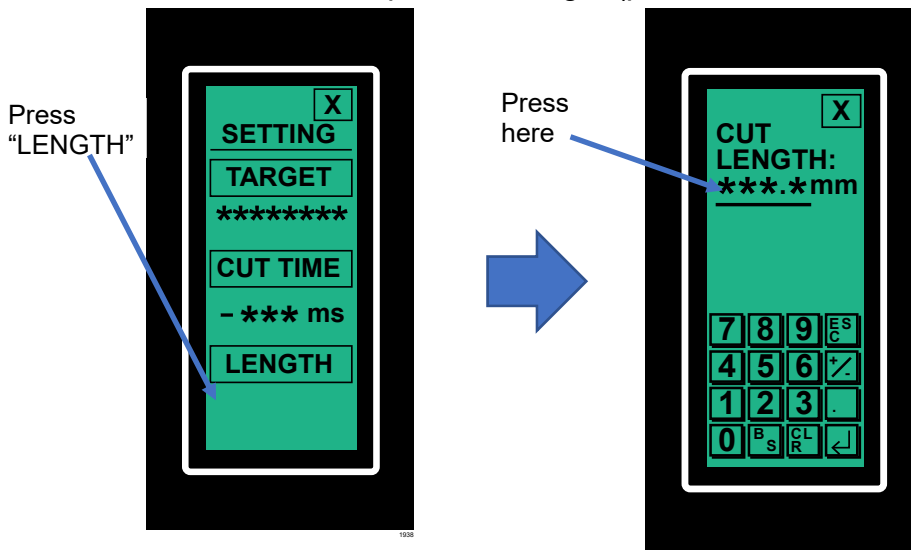

Example:



Cut length has been set. The feed motor will send 100.5mm of film.

- Press "CUT TIME" to set up the cutting motion time (press the "star" to access the keyboard).

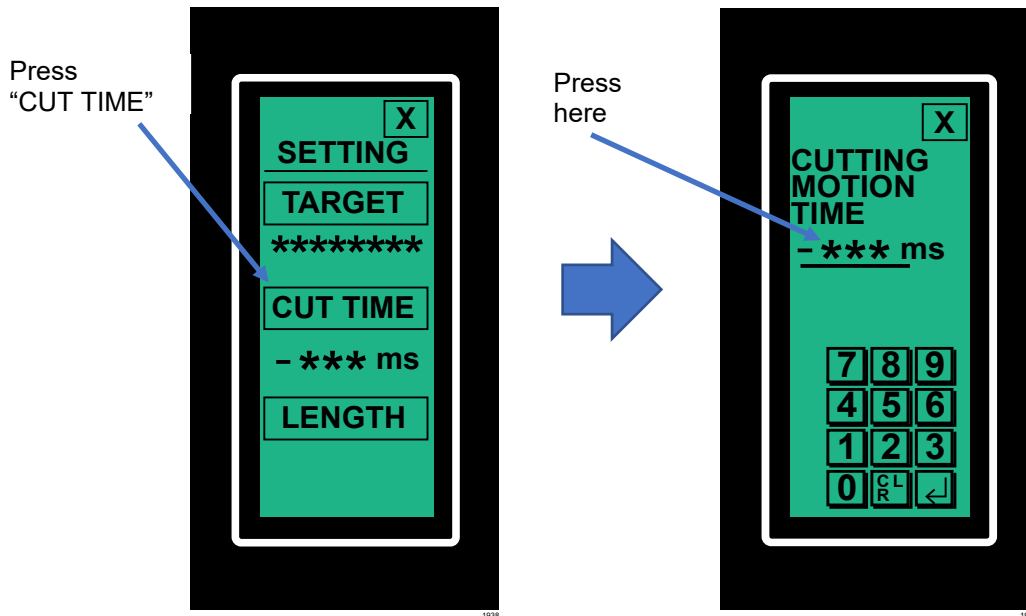

Example:



Cutting motion time has been set. The setting range is about 100-250ms.

Press the  twice. The screen returns to the main function screen.

- Press "MANUAL" for manual function screen.

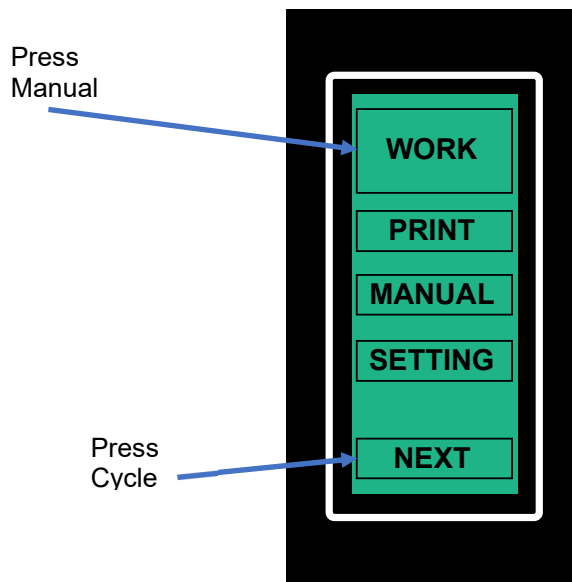

Press "CYCLE", Test run the machine to check if it is working properly. (You must test run at least 3 times to check the Label)

Press  to jump to the main function screen.

4. Press "WORK" for the work screen.

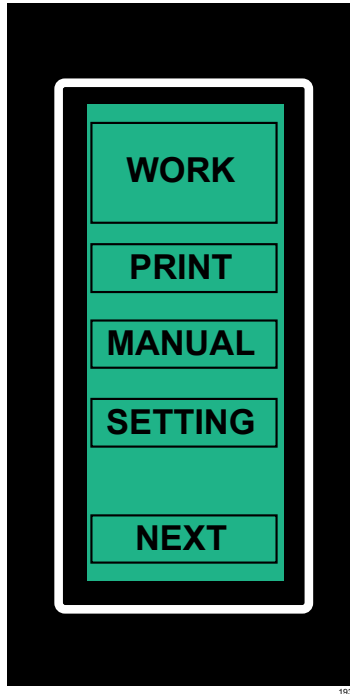

5. Test run with the actual object being sleeved and adjust the work detect sensor's position to shoot the label over the bottles accurately.

- ** If the label falls too soon, before the bottle is underneath the center line of the mandrel, move the sensor towards the mandrel (as shown in Picture 1).
- ** If the label falls too late, after the bottle has passed underneath the center, line of the mandrel, move the sensor away from the mandrel (as shown in Picture 2).

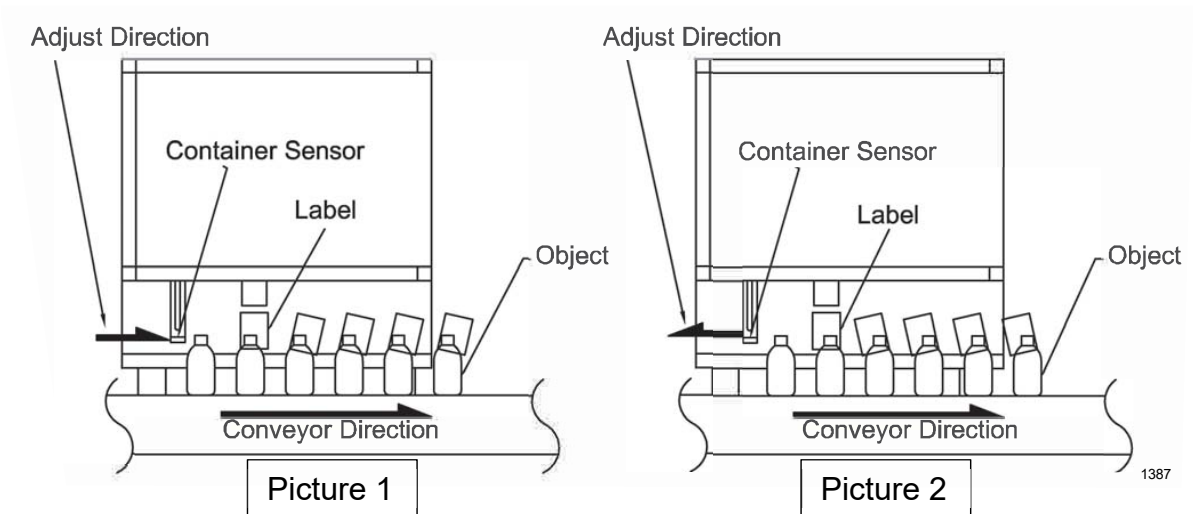

B. Using the reading print sensor

1. Press the "PRINT" switch.

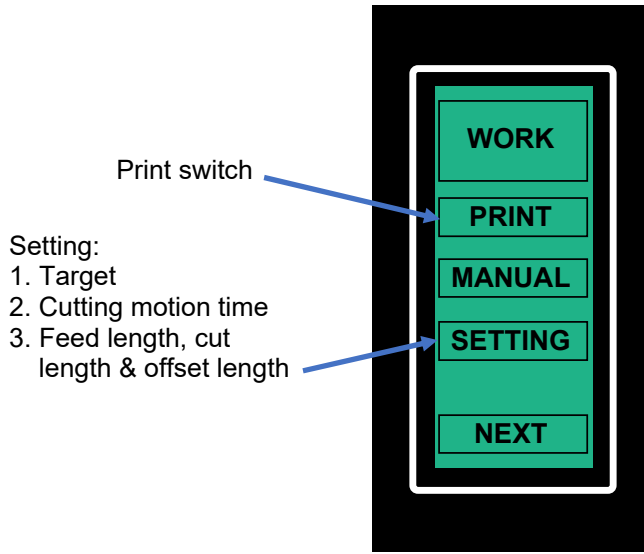

2. Press "SETTING"

Press "LENGTH" to set up the cut length (press the "star" to access the keyboard).
 (Press the star, and the keyboard will appear.)
 Measure the frame length by ruler, then key in the data.

EXAMPLE:



Cut length has been set. Mean frame length is 150.5mm.
 Set the offset makeup to "0"
 (Press the star, and the keyboard will appear.)



Press  to jump to the setting function screen.

Press "CUT TIME" to set up the cutting motion time
 (Press the star, and the keyboard will appear.)
 Enter the digits of time needed.

EXAMPLE:



Cutting motion time has been set. The setting range is about 100-250ms.

Press the  twice. The screen returns to the main function screen.

3. Press "MANUAL" for manual function screen.

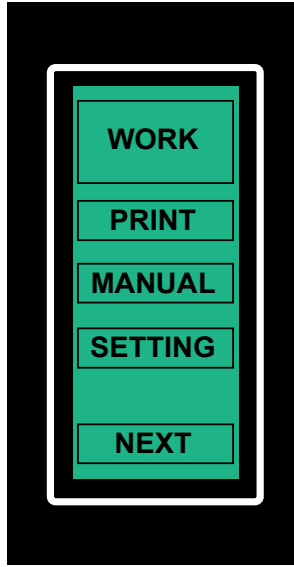

Press "CYCLE", Test run the machine to check if it is working properly. (You must test run at least 3 times to check the Label).

Next, determine the offset number.

Press the  twice. The screen returns to the main function screen.

4. Measure the offset with a ruler

EXAMPLE:

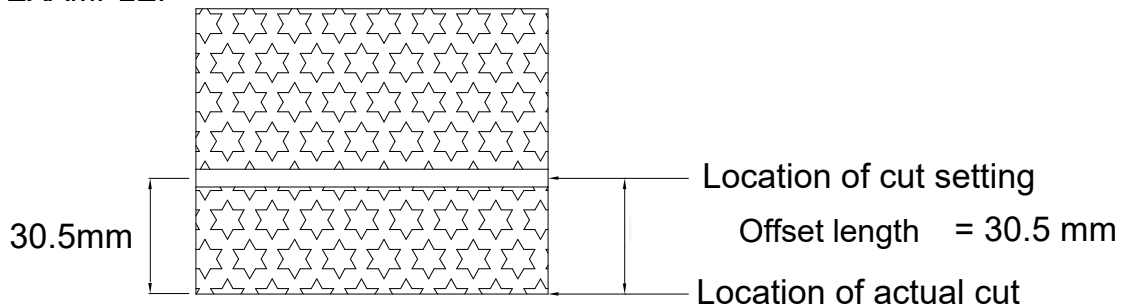

1389

5. Modify the offset length setting.

Press "SETTING", then press "LENGTH" to set up the offset length.

(Press the star, and the keyboard will appear.)

EXAMPLE:



Press the  twice. The screen returns to the main function screen.

6. Repeat step 4 of above to check where the labels are being cut after you have entered the offset length.
7. If the label's actual cutting location is below the location of the planned cut, then the offset length should be increased.
- ** If the label's actual cutting location is above the location of the planned cut, the offset length should be decreased.
8. Turn on the work switch.
9. Test run with the actual objects being sleeved, adjust the work detect sensor's position to shoot the labels onto each bottle accurately.

** If the label falls too soon, before the bottle is underneath the center line of the mandrel, move the sensor towards the mandrel (as shown in Picture 1).

** If the label falls too late, after the bottle has passed underneath the center line of the mandrel, move the sensor away from the mandrel (as shown in Picture 2).

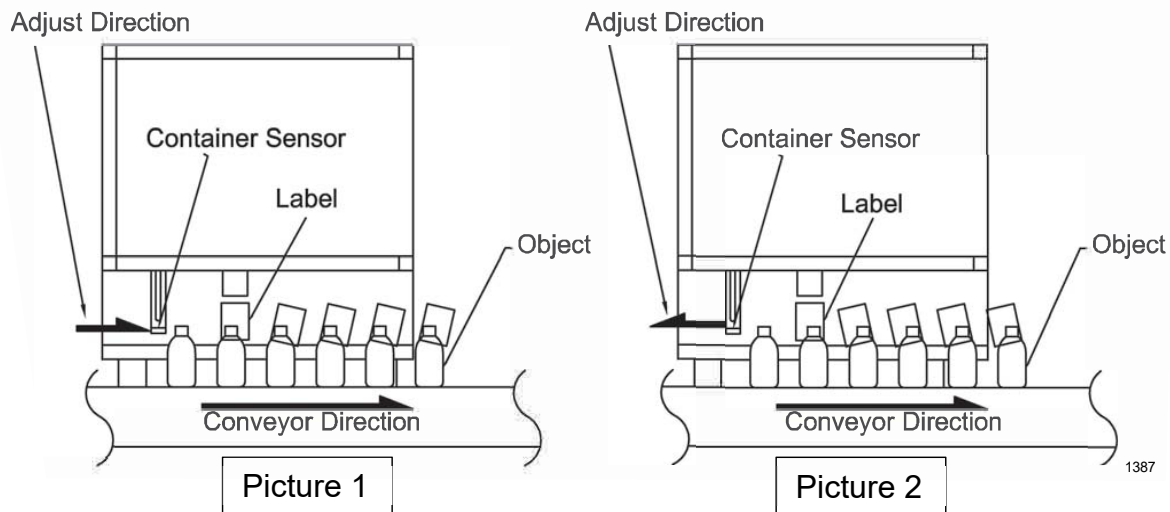

Printing and none-printing

None-printing mode

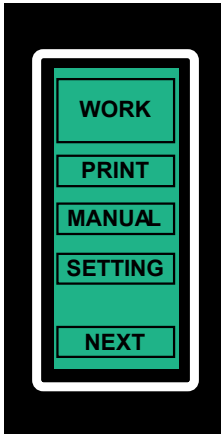

“PRINT” switch is off.

CUT LENGTH = 100.0 mm

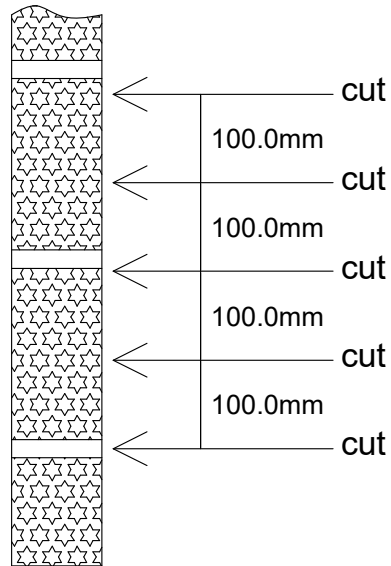

Printing mode

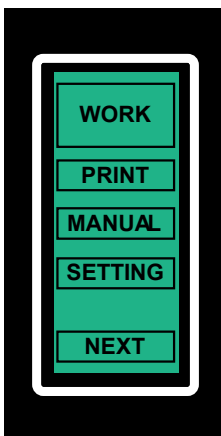

“PRINT” switch is on.

CUT LENGTH = 100.0 mm

Sends 100mm more when printing electric eye signal switches from on to off.

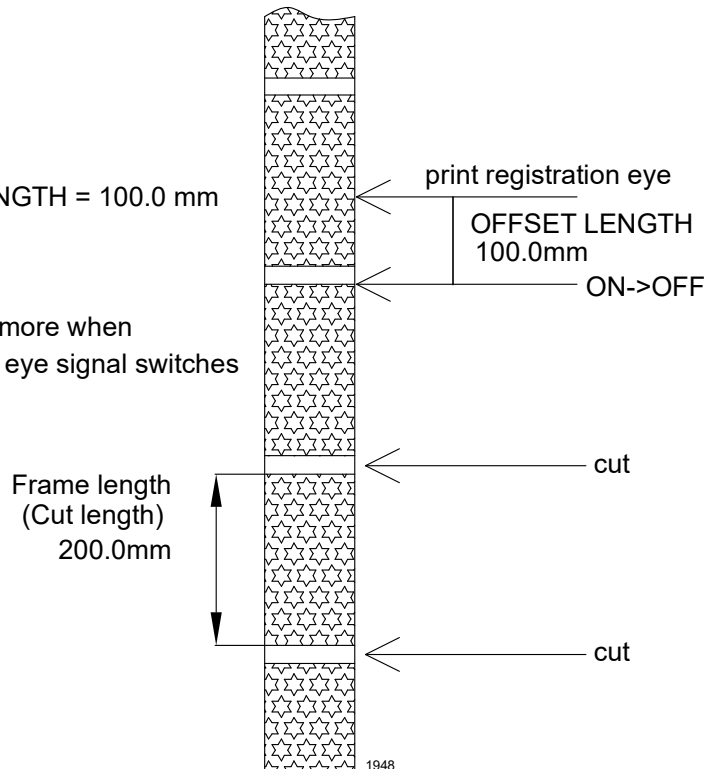

Check registration on film. Keep a pair of scissors handy to cut off the film at clear spot in the film. Make sure that it is “un-crikkled”.

Touch Panel Screens (H.M.I.)

Screens

Screen 10

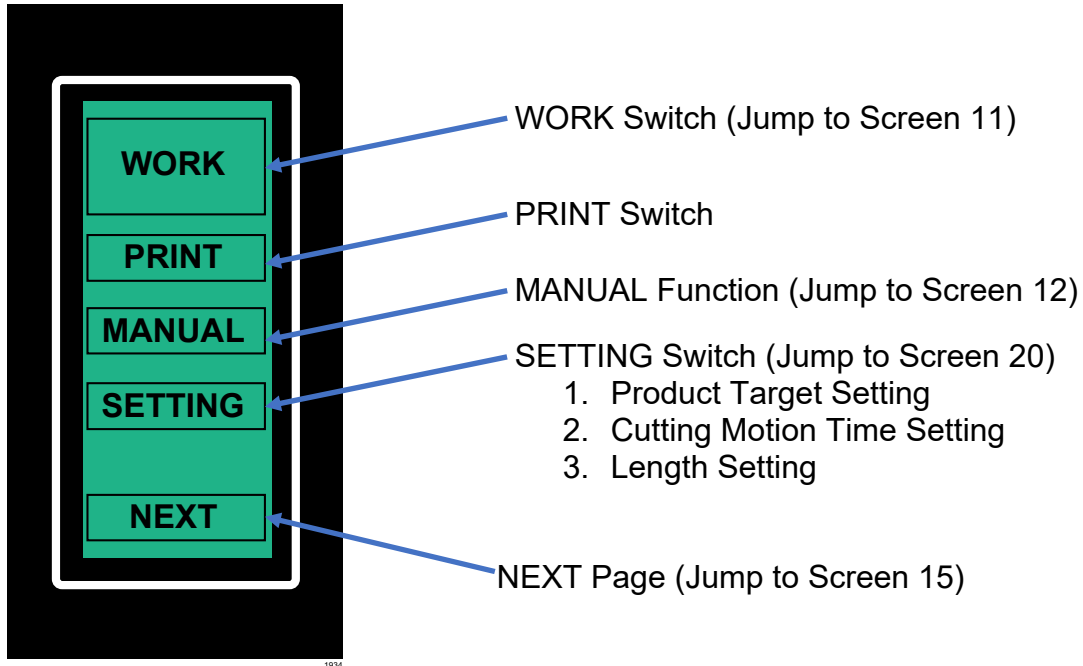

Screen 15

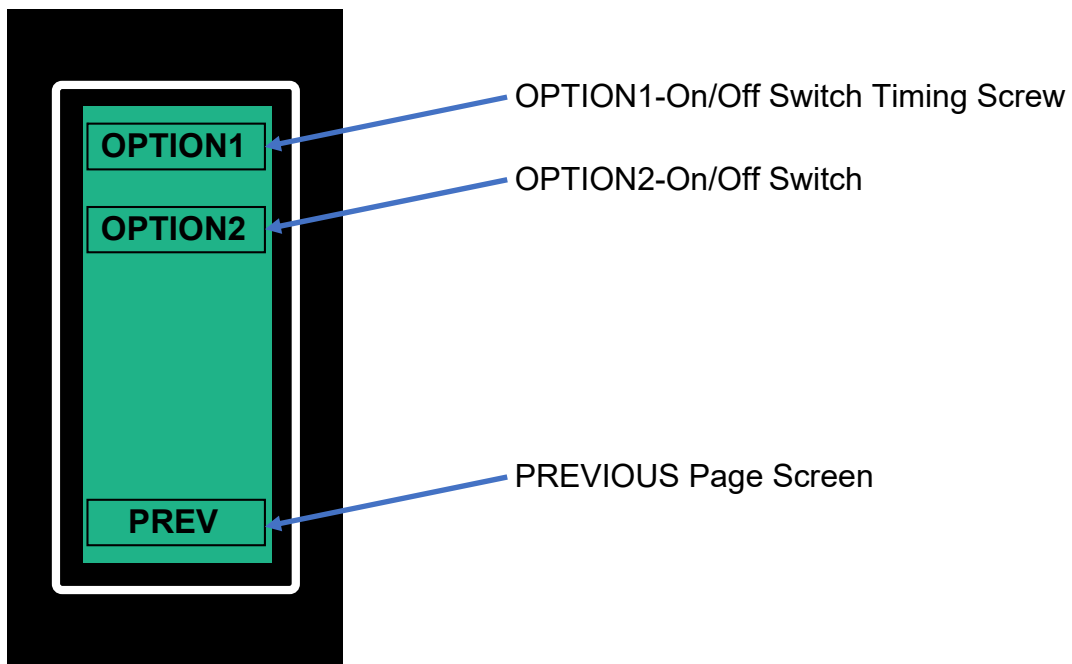

Screen 12

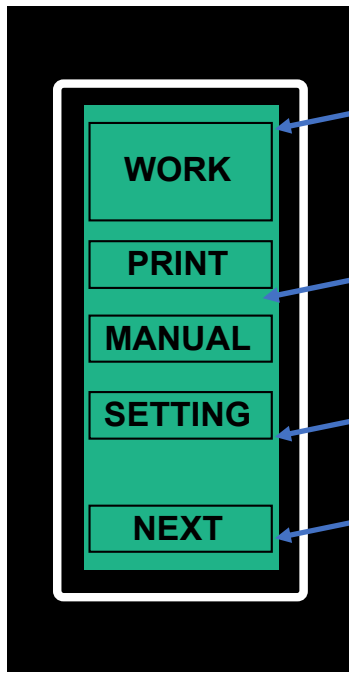

Jump to Screen 10

Feeding Film

CUTTER

FEED + CUT

Screen 30

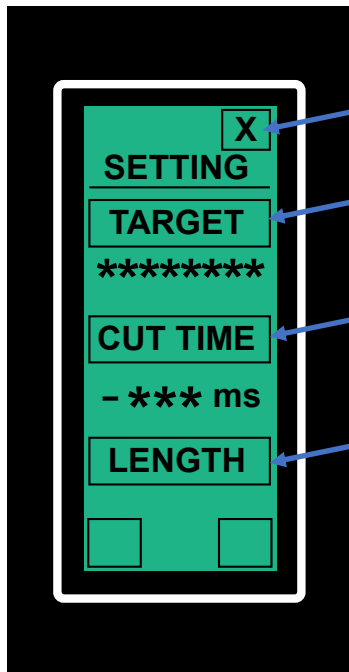

Jump to Screen 10

Jump to Screen 31

Jump to Screen 33

If the PRINT key is on,
Pressing the key will jump to Screen 14
If the PRINT key is off,
Pressing the key will jump to Screen 13

Screen 13

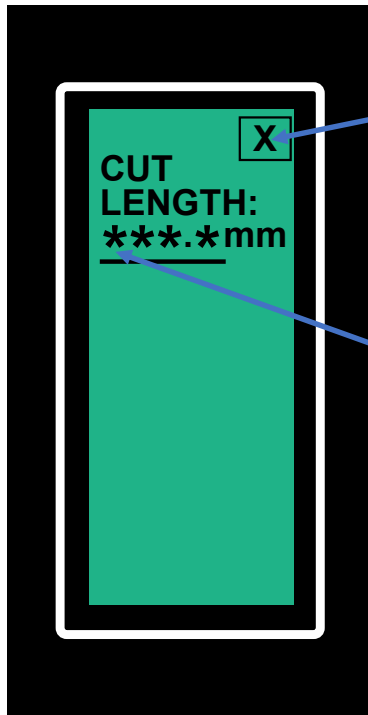

Jump to Screen 30

Press here to access keyboard

Screen 14

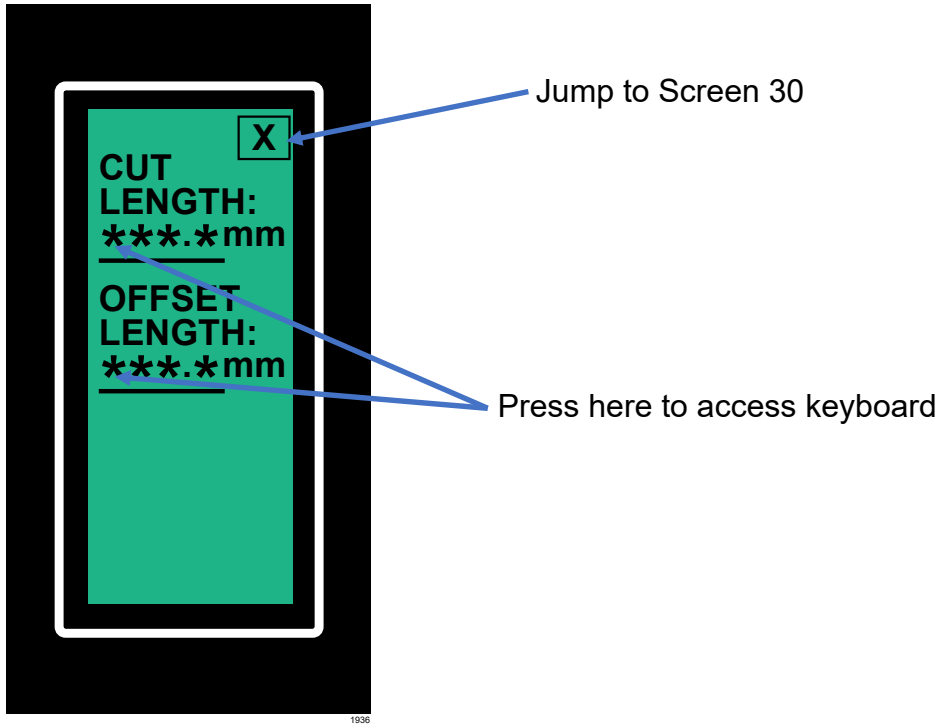

Screen 31

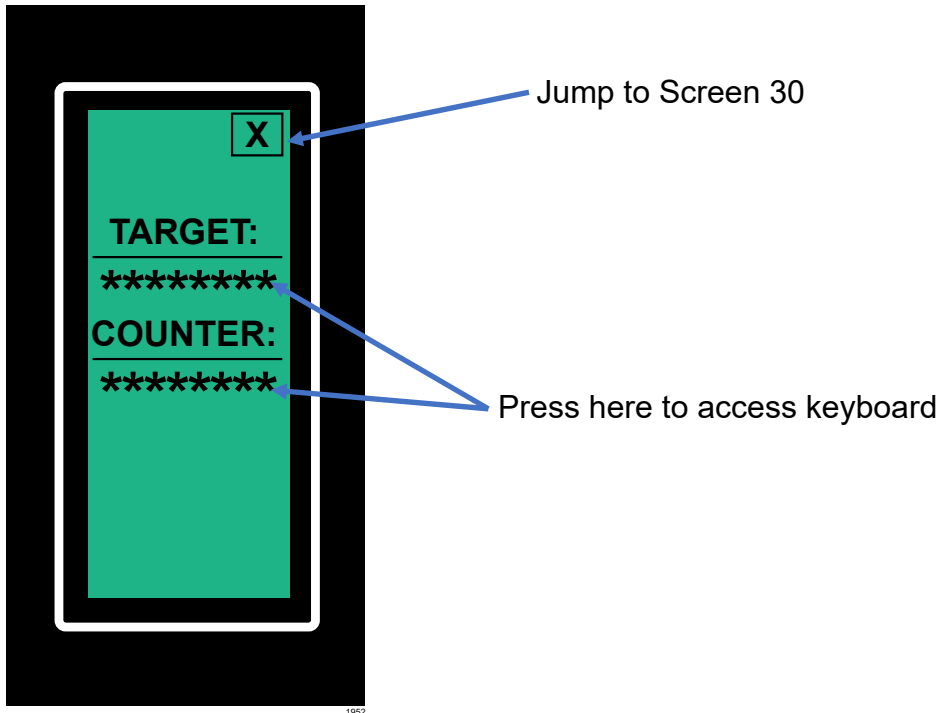

Screen 33

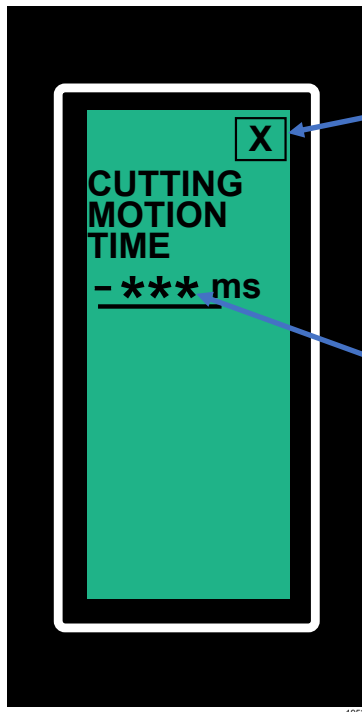

Jump to Screen 30

Press here to access keyboard

Screen 11

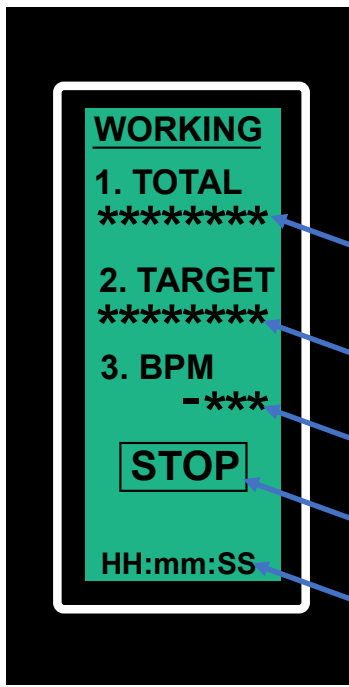

Press here to access keyboard

Press here to access keyboard

Bottles per minute (Piece/Min.)

Work Stop, Jump to Screen 10

Clock- Hour/Minutes/Seconds

Maintenance

Changing Cutter Blades

Ensure that the power is off, and that the unit is unplugged.

Open the door. Remove the Mandrel and place it in a safe place.

Remove the Cutter Cover, two (2) Socket head cap screws, and set aside.

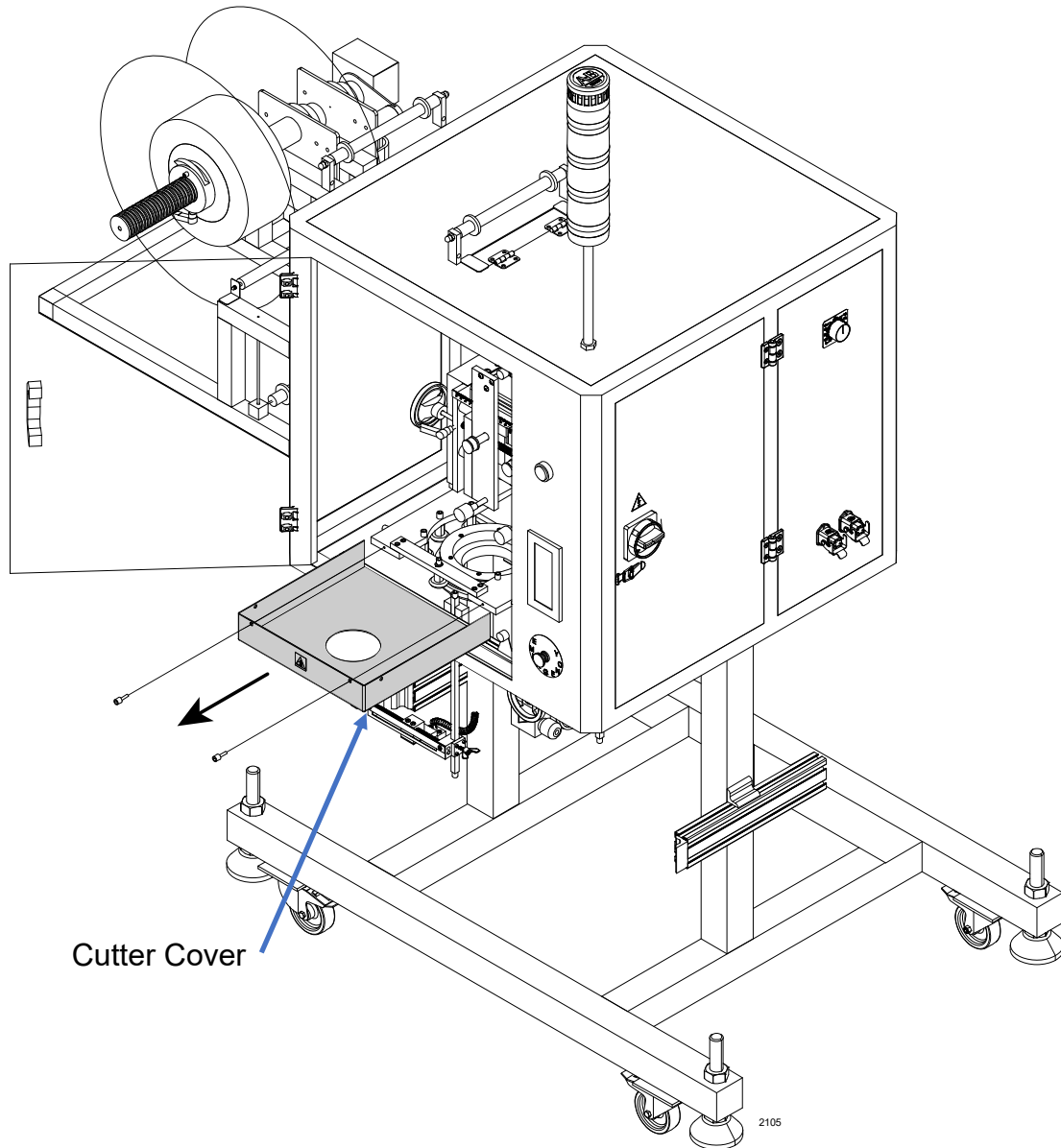

Kneel under the machine and locate the Cutter Blade Assembly.

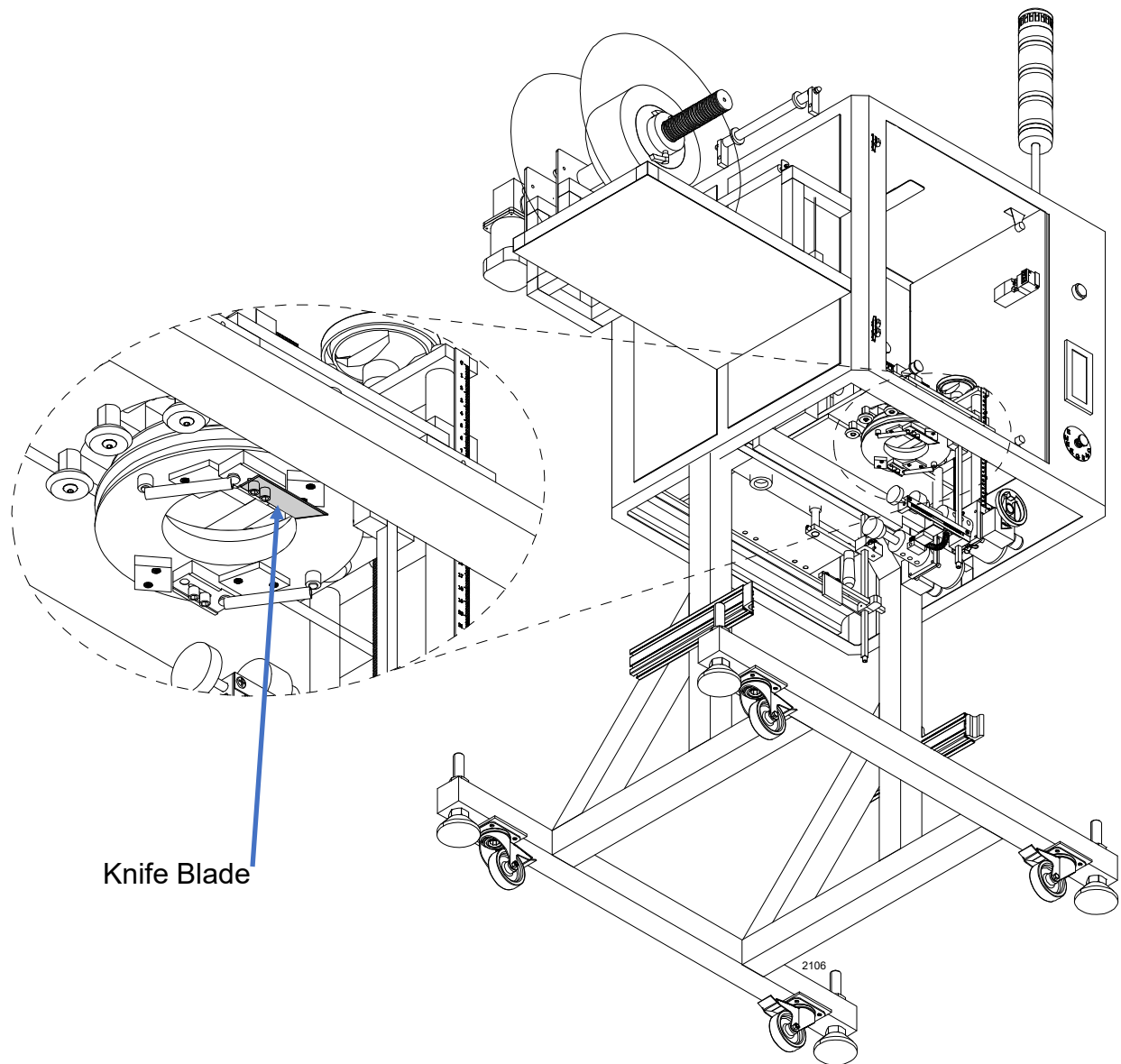

BLADE IS SHARP!

Remove Socket Head Cap Screws and Knife Blade. Replace Blade and Screws in reverse order.

After replacing blade, replace Cutter Assembly cover and insert it back into the LX-100. Place old blades in a “sharps” container and dispose of them (recycle if possible).

LX-100

Weekly

- Use a *light brush* to clean fibers off film registration eye (do not use compressed air, as this may damage fibers).
- Use a cloth to clean off the Motion Detector Sensor eye (for bottle sensing under the mandrel) and reflector.

Every three weeks

- Replace all cutter blades on cutter unit, making sure all are timed correctly.
- Check tension of cutter belt when re-installing unit. Make sure main cutter drive belt is tight and undamaged.
- Remove back cover of machine and check tension of film feed drive belt, and tightness of set screws and screws securing motor.
- Check bearings inside mandrel, make sure they spin freely. Clean as necessary.
- It is acceptable to use a little light, food-grade oil once the bearings are free of dust.
- Verify that supporting rollers for mandrel can spin freely; clean as necessary.

Every six months

- Check for wear on (urethane) film feed drive rollers. If the machine is continuously in use, it should not be necessary to clean these rollers too often,

however, depending on the film, there may be a build-up of shiny, plastic residue on the rollers which could cause the label to slip as it is being fed (leading to loss of registration). If necessary, the rollers can be cleaned with distilled (or de-ionized or reverse osmosis filtered) water.

- **DO NOT USE ALCOHOL ON THE URETHANE ROLLERS.**
- Check for wear of all belts.
- Check adjustment of idler on dancer, making sure it is engaging with drive roller
- Apply grease to gears and bearing blocks for head height adjustment, applicator height adjustment, and mandrel holder.
- Check for excessive dust in electrical enclosures. Vacuum as necessary.

Annually

- Replace bearings inside mandrel.
- Replace supporting (metal) rollers for mandrel.
- Replace bearings of cutter unit.
- Check bearings in idlers of film feed drive (remove right-hand machine side cover).
- Check bearings of applicator assemblies.
- Check lubricant in reducer for head height adjust. Replace as necessary.

Every two to three years

- Replace film feed drive belt, and idler bearings.
- Replace film feed rollers.

- Replace cutter belt and cutter drive belt.
- Replace dancer drive rollers.
- Replace applicator drive belts.
- Replace applicator bearings.
- Replace applicator wheels.

Unwind System

Daily

- Check to make sure film end eye (fiber) is not caked in dust; clean as necessary – use a *light brush*.

Every six months

- Check drive rollers on dancer for wear; replace as necessary; check adjustment of dancer idler, making sure it is engaging the drive rollers.

Every two years

- Replace bearings on dancer assembly replace dancer drive roller.

The following maintenance items should be checked regularly to insure continued reliability.

Frequency indicates how often you can expect to replace the item given a 24-hour, 5-day per week operation at 300BPM.

Maintenance Item	Expected frequency of replacement
Cutter blades	2 Weeks
Perforator blades	1 Year
Cutter timing belts	2 Years
Film feed timing belt	2 Years
Perforator linkage	6 Months
Perforator anvil	2 Years
Brush-down flails (depending on container material)	1 Month
Bearings on mandrel (Film feed and applicator wheel positions)	1 Year
Film feed drive rollers	3 Years
Applicator wheels	3 Years
Applicator wheel timing belts	2 Years

Troubleshooting

General

Problem	Cause	Solution
---------	-------	----------

Power shutting down	Internal plant or machine shut-off	<ol style="list-style-type: none"> 1. Turn switch to "OFF" position, and re-start 2. Replace switch if loose.
Motor stops working	<ol style="list-style-type: none"> 1. Fuse is blown 2. Motor's phase is incorrect 3. The stepper and servo motor drives have failed-setting parameters are incorrect 4. Motor burned out 	<ol style="list-style-type: none"> 1. Replace the fuse 2. Check main power and cords 3. Check to see if stepper and servo motors are ok and that the parameters are set correctly 4. Replace motor.
PLC Control is incorrect	<ol style="list-style-type: none"> 1. Switch is off 2. No power connection to PLC 3. No signal at sensor 4. Relay is not working 5. PLC is damaged 	<ol style="list-style-type: none"> 1. Turn switch to "RUN" position 2. Check the source voltage 3. Check to see if sensor is working, and is correctly wired 4. Check to see if there is sound at the relay and the lines are correctly connected. Replace relay if it is damaged. 5. Replace the PLC
HMI display problems	<ol style="list-style-type: none"> 1. No power to HMI input 2. No signal from PLC 3. HMI is damaged 	<ol style="list-style-type: none"> 1. Check the DC Voltage 2. Check the wiring connections between the PLC and the HMI 3. Replace the HMI

Problem	Cause	Solution
Sensor is not working	<ol style="list-style-type: none"> 1. The relay is not functioning 2. No signal at the sensor 	<ol style="list-style-type: none"> 1. Check to see if the sensor is in the right position and

	<ol style="list-style-type: none"> 3. Sensor is damaged 	<p>that the gap is correct</p> <ol style="list-style-type: none"> 2. Check the sensor's signal contacts and check the DC Voltage 3. Replace motor.
<p>Cutter and feeder device malfunctioning</p>	<ol style="list-style-type: none"> 1. The relay is damaged 2. The cutter is damaged 3. The cutter and feeding stroke is damaged 	<ol style="list-style-type: none"> 1. Check to see if there is sound at the relay, and if the wiring is correct, replace the relay 2. Replace cutter with the spare. 3. Check to see if there are foreign objects in the stroke, and see if it is damaged. Replace if damaged.

Specific problems while running machine

Problem	Correction
---------	------------

Label consistently forward, or behind container	Adjust <i>Applicating Delay</i> parameter (from SETTINGS screen), or move Motion Detector Sensor eye upstream or downstream. Be sure to verify also that the containers are coming out of the Timing Screw so that they will be centered under the Mandrel. Motion Detector Sensor eye and reflector.
Label sometimes behind container (too late)	Width of Applicator Wheels too wide Applicator wheels running too slowly
Labels tearing on Mandrel	Check the pressure of the Film Feed Rollers * Correct pressure for Film Feed is “all the way in” using the IN/OUT buttons Check Pressure of support Rollers * Support Rollers should rotate but not spin freely
Labels jamming inside Cutter unit	Check for correct Cutter HOME POSITION Measure the layflat width of the film to confirm that it is within specifications. Check WORK DETECT timing
Labels “bunching” at Film Feed Rollers	Measure the layflat width of the film to confirm that it is within specifications
Labels not being shot cleanly from the base of the Mandrel	Check the pressure and height of the Applicator Wheels
Label material folding over within the Dancer on the LX-150	Make sure the unwind system (UR2) is lined up with the LX-100 door and that the center of the roll of labels is in line with the Fin of the Mandrel
Label is splitting on the Fin of the mandrel	Verify the layflat of the label (tolerance is usually +1.0/-0.0) mm). Check for burrs on Fin of Mandrel.
Perf. depth is inconsistent	Check the Perforator Linkage - replace if needed. Check the Perforator assembly for loose components and fasteners.

Problem	Correction
---------	------------

<p>In <i>Print Registration</i> mode, the label cut position is inconsistent</p>	<p>Check that the Film Feed Rollers are not skidding on the label (i.e. Film Feed Rollers not tight enough); verify that the label material is not getting jammed or impeded above the Film Feed Rollers; check for lint or dirt between the fibers of the <i>print registration</i> eye; also check the <i>eye-mark</i> of the label to make sure that the opaque~transparent transition is not “cloudy” (this would be a materials problem); you can narrow the cause down by running the machine in FIXED CUT mode to see if the behavior changes</p>
<p><i>Application Fail</i> fault keeps occurring even though there is no label jam</p>	<p>Increase the value of the Application Fail TIMER and run the machine again; check the position and adjustment of the <i>Application Fail</i> photo-eye – the LED should light only when there is a label just below the Mandrel (the amplifier for the eye is located beneath the left-hand side cover of the LX-150). *correct <i>Application Fail</i> photo-eye position is between base of Mandrel and cap of container</p>
<p>Timing Screw is starting and stopping erratically</p>	<p>Verify that Infeed Low and Discharge Low photo-eyes are not contaminated with dust or condensation</p>
<p>Label is splitting along the crease</p>	<p>Check the UR2 Reel Assemblies and Dancer and LX-150 Dancer and Mandrel Fin for burrs which may be damaging the label; also, film rewind tension may be too high (defective labels)</p>
<p>Label is splitting along the seam</p>	<p>This is most likely a label materials problem – insufficient solvent on the seam – change to a different roll of labels</p>
<p>Film is twisting on Mandrel</p>	<p>Create more back-tension by slowing the Inner Dancer motor</p>
<p>A servo motor constantly generates an Error Message</p>	<p>Most likely cause is mechanical binding (e.g. Perforator: perforations may be too deep; Cutter: label material may have accumulated in the Cutter unit; Film Feed: label may be getting caught above the Mandrel)</p>
<p>A VFD constantly generates a fault and shuts down, requiring a <i>reset</i> of the VFD</p>	<p>Most likely cause is mechanical binding (e.g. Inner Dancer VFD: film jam in Dancer)</p>

Motion Detector

Motion Detector Sensor Details

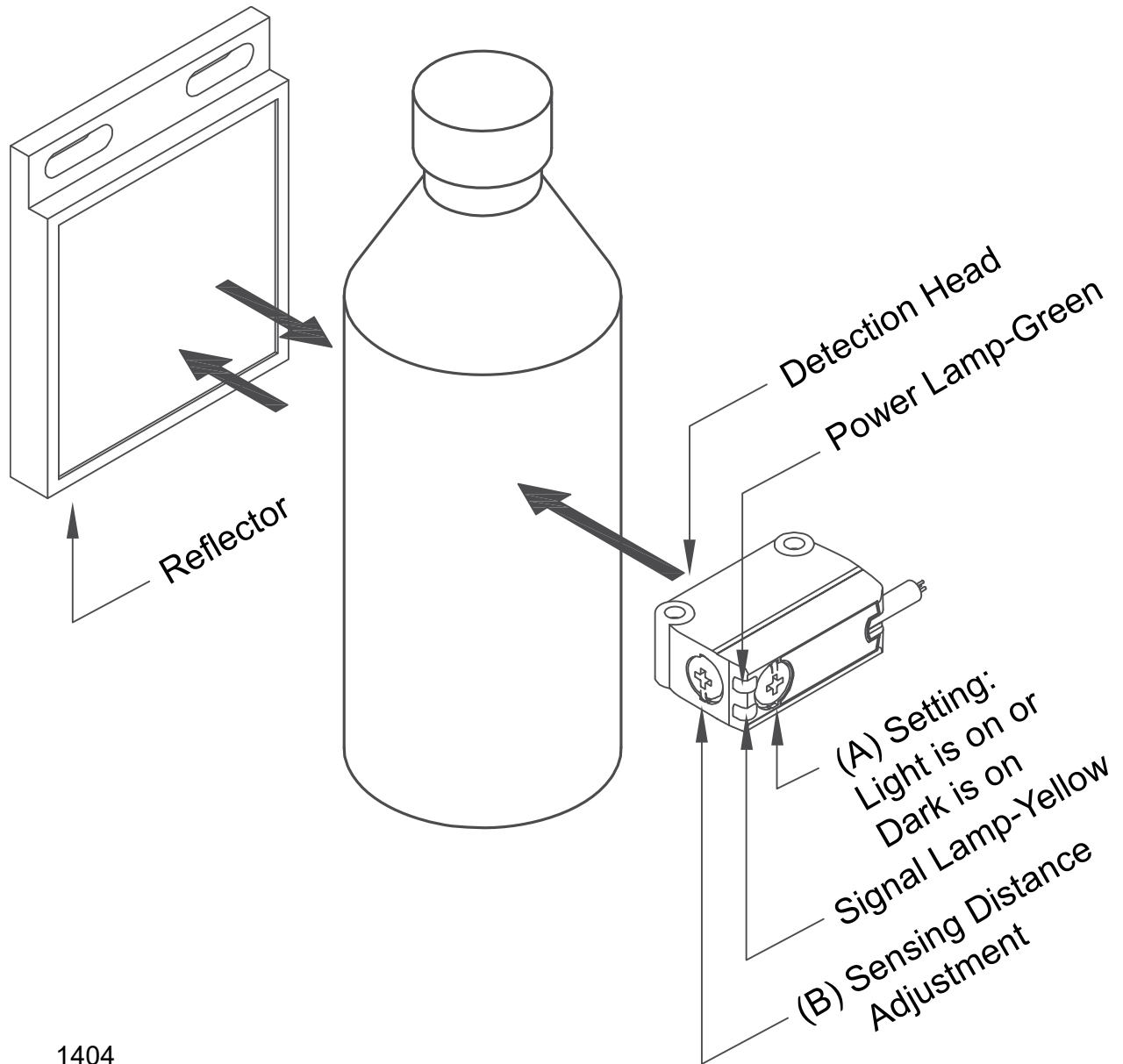

Motion Detector Sensor Setup

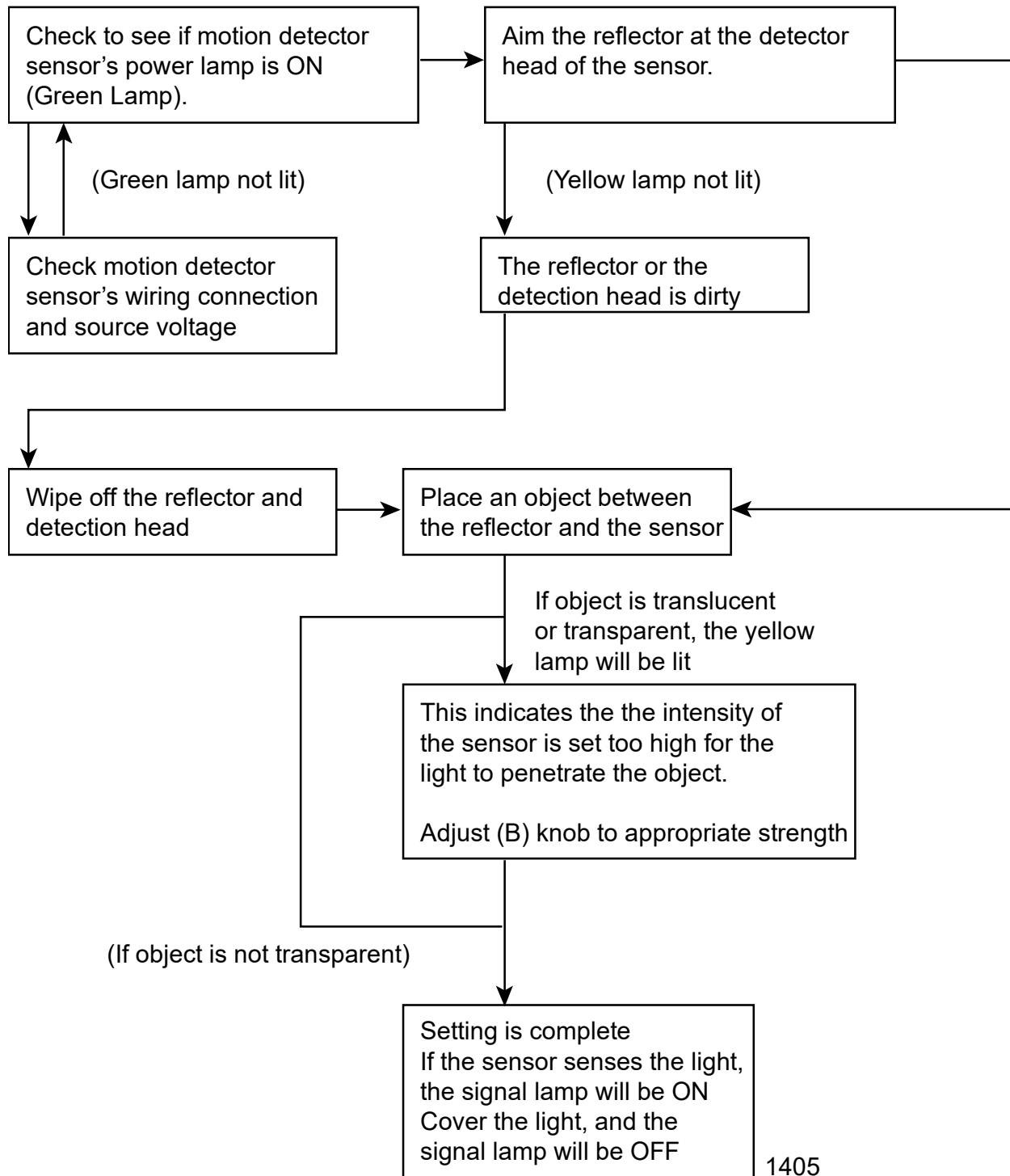

Print Reading Sensor details

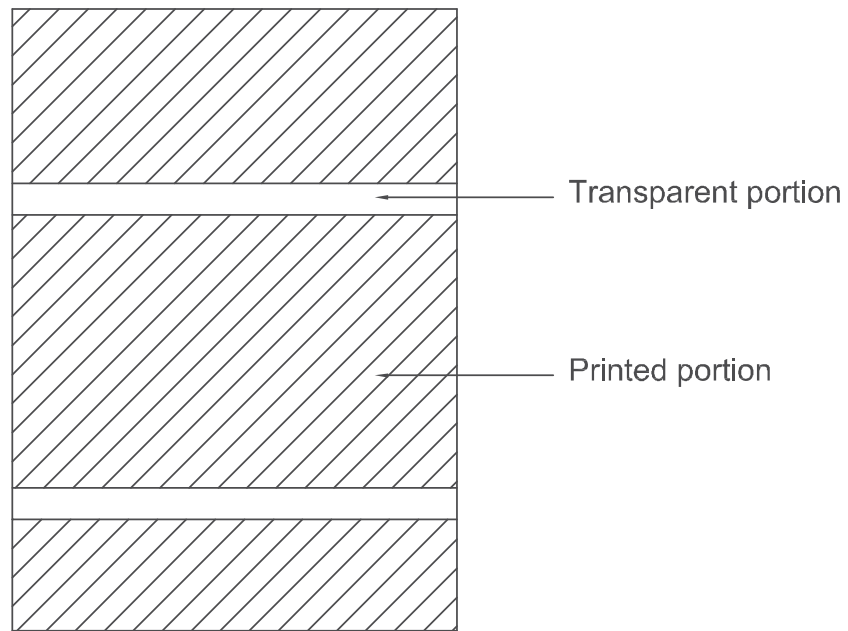
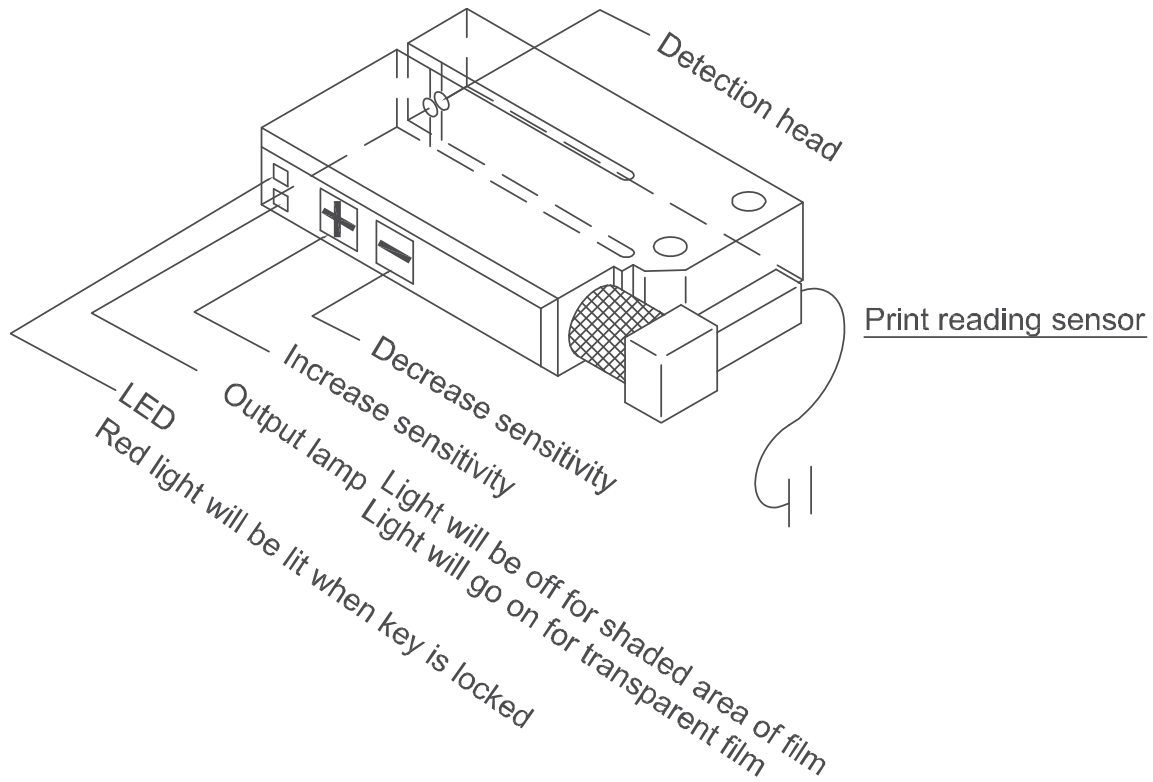

Printed label to be scanned for setup

Print Reading Sensor setup

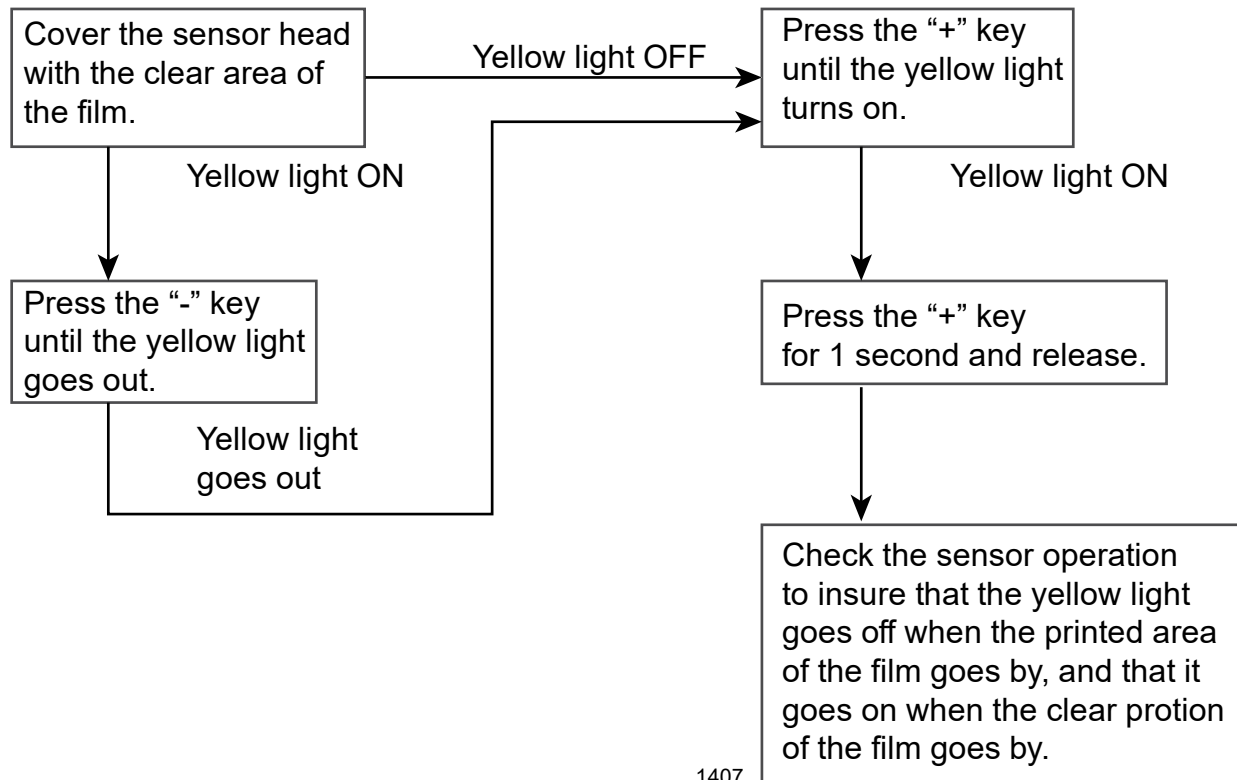

1407

Note:

- When pressing "+" or "-", the red light will turn on.
- Pressing the "+" or "-" key for 3 seconds will turn on the on/off key lock function. When red light is on, the sensor's sensitivity cannot be adjusted.
- The dark/light switching can be set if you press the "+" and "-" keys simultaneously (6s).
Factory setting: Transparent film = yellow light on
shading film = yellow light off
- The printing sensor has four wires:
 - Brown- Connects 10-30V
 - Blue- Connects to OV
 - White- Connects to NPN type PLC infeed
 - Black- Connects to PNP type PLC infeed
 This machine uses an NPN connection
(The white wire is connected to the PLC, and the black wire is not used.)

Operation Appendix

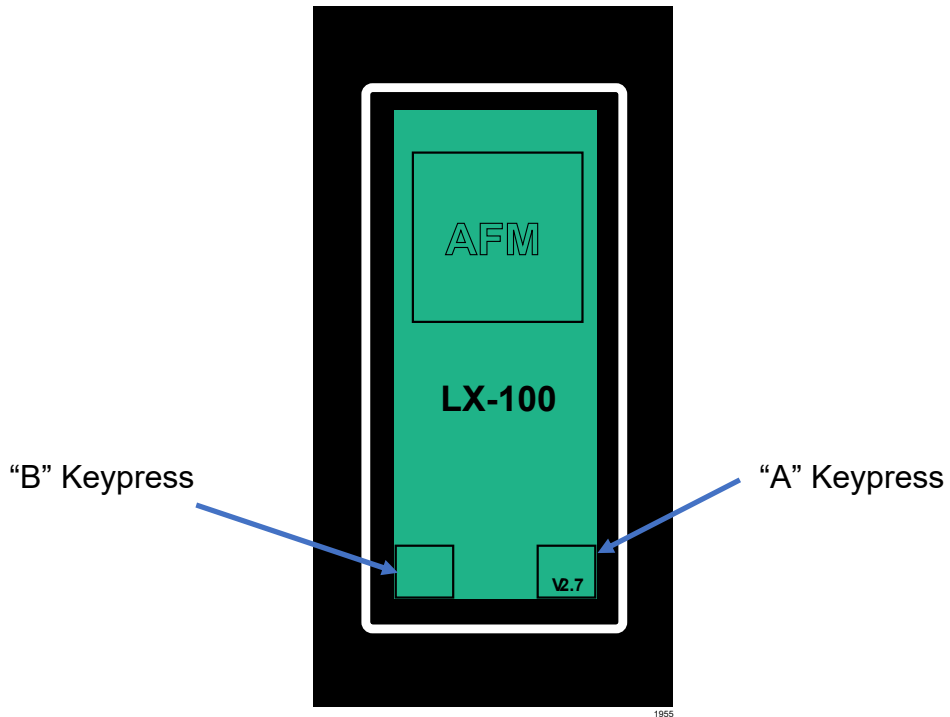

Press “A” keypress over 3 seconds, then release
Press “B” keypress to jump to “Display Mode” Screen

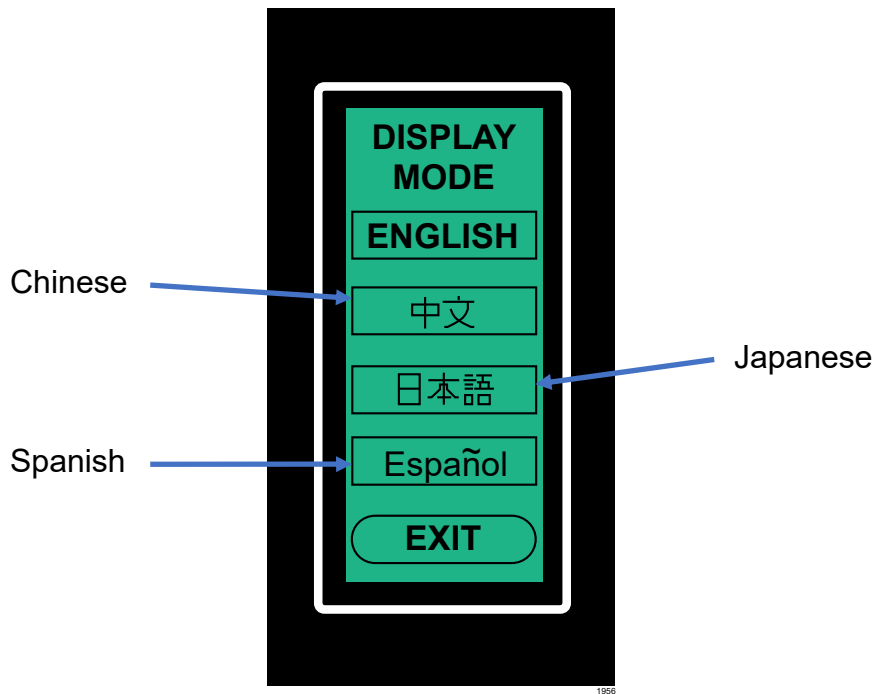

Display Mode Screen

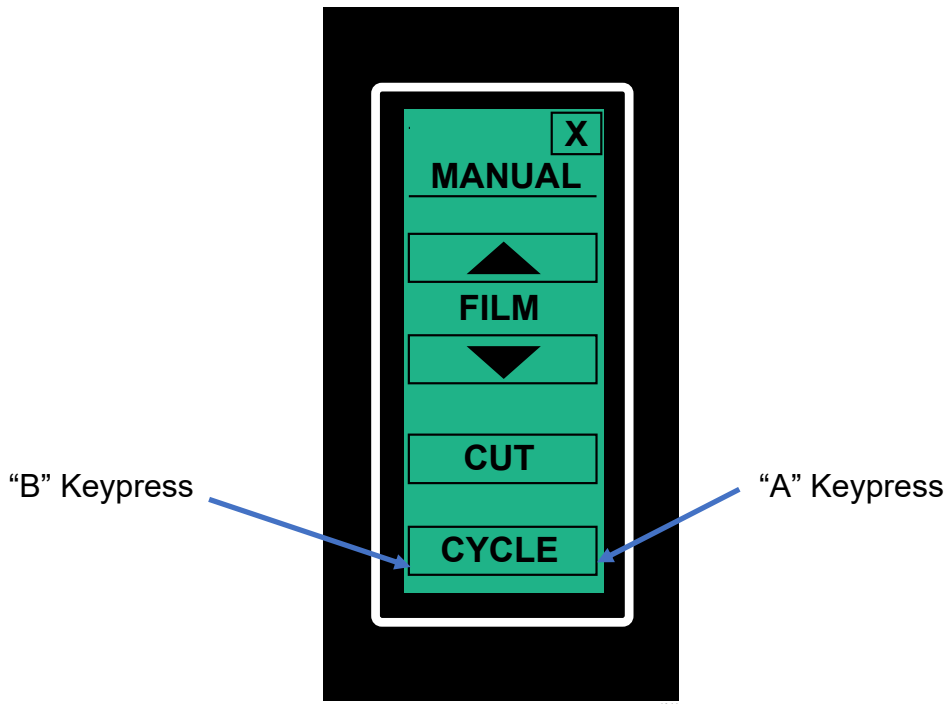

Press "A" keypress over 3 seconds, then release
 Press "B" keypress to jump to "Function Setting" Screen

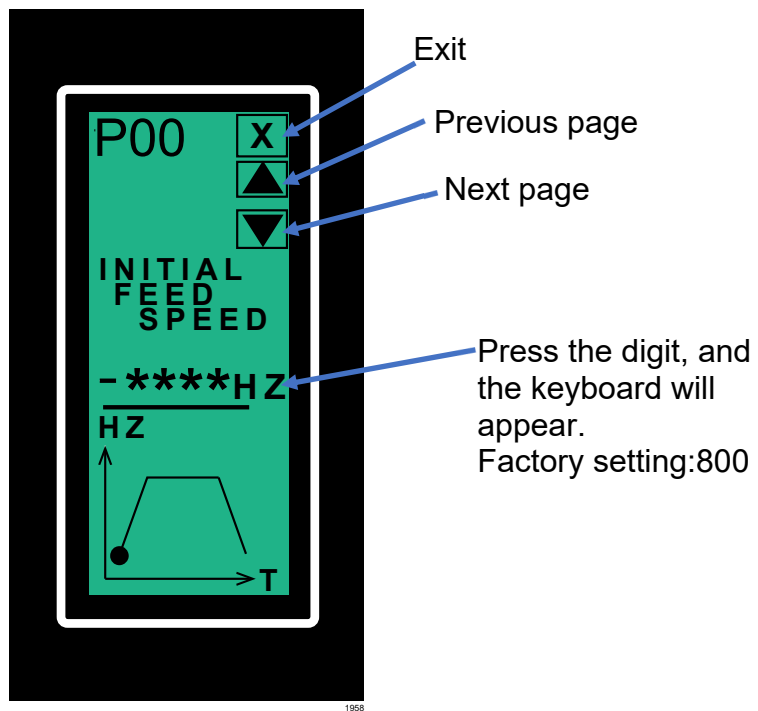

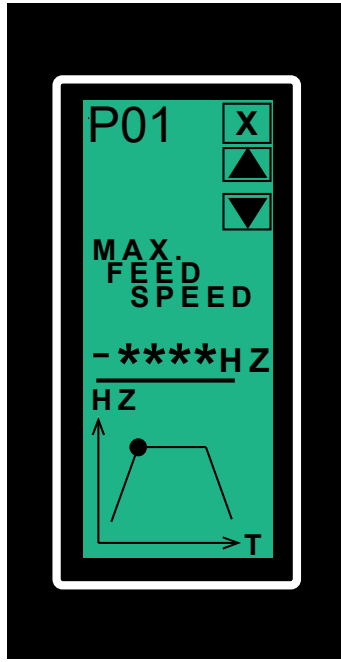

Factory Setting: 1700

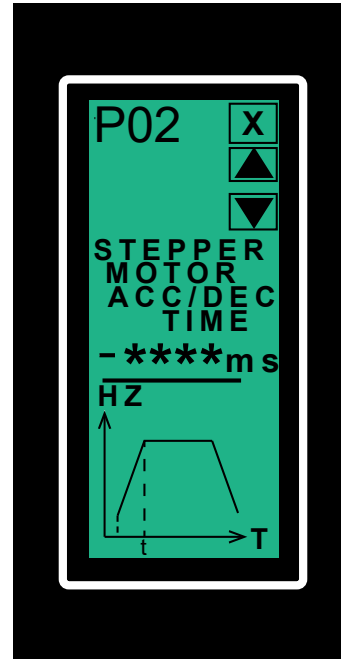

Factory Setting: 150

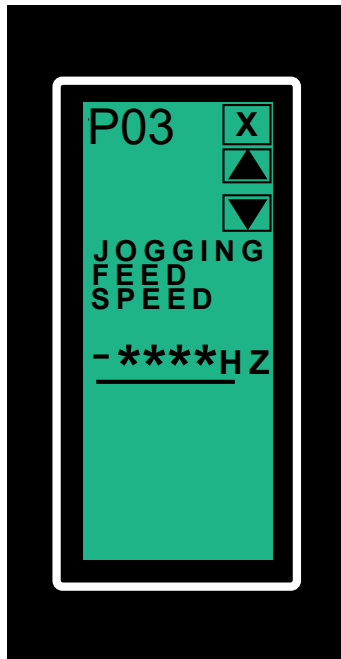

Factory Setting: 800

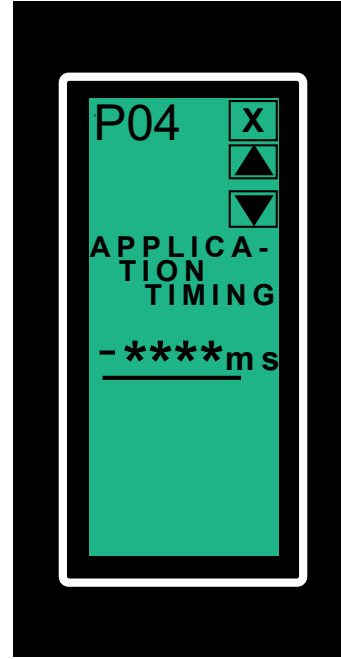

Factory Setting: 0



Factory Setting: 100.0

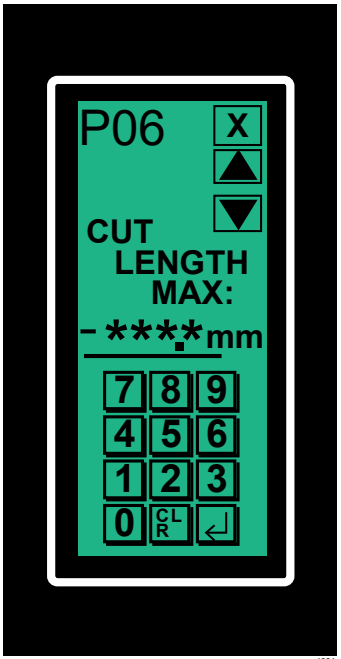

Factory Setting: 250.0

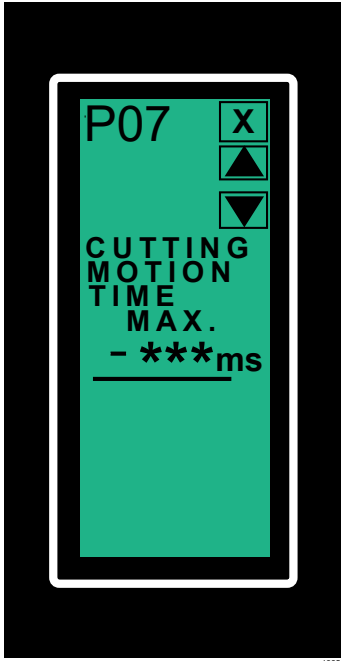

Factory Setting: 600

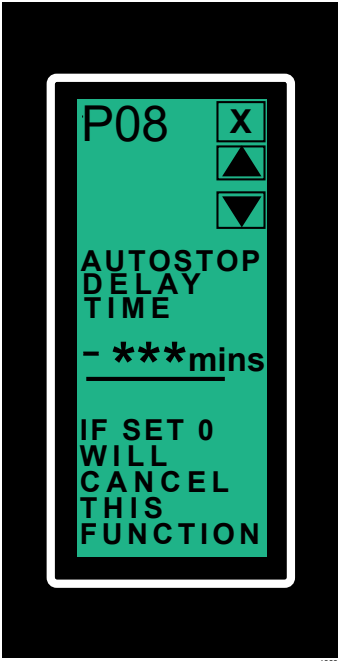

Factory Setting: 0

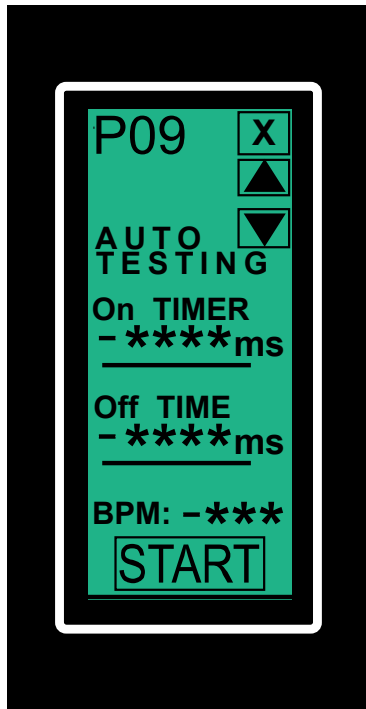

Factory Setting:
500

500



Factory Setting: 600

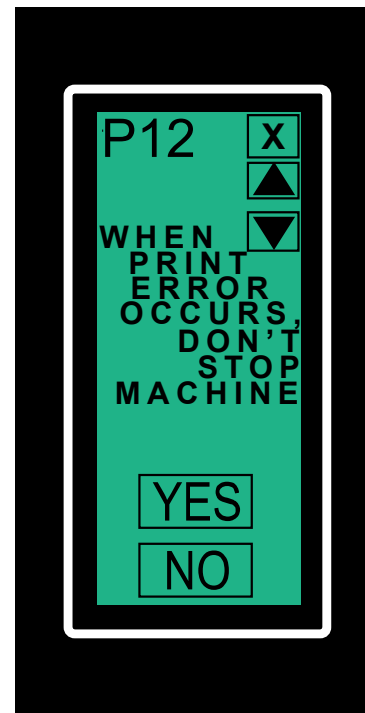

Factory Setting: YES

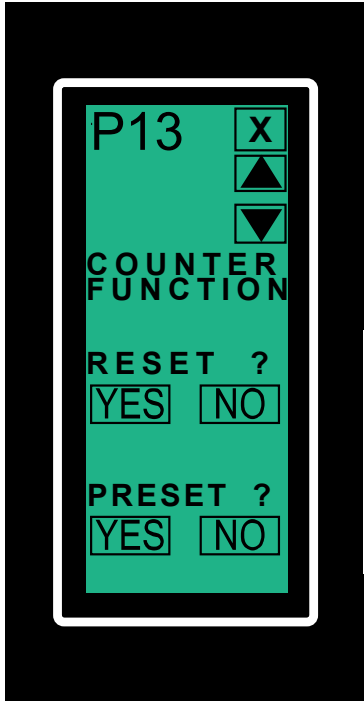

Factory
Setting:
YES

YES

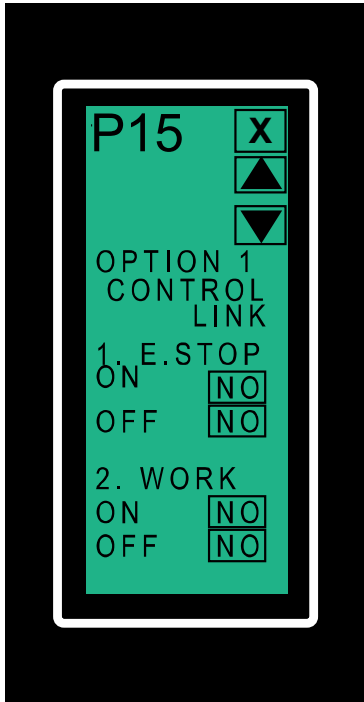
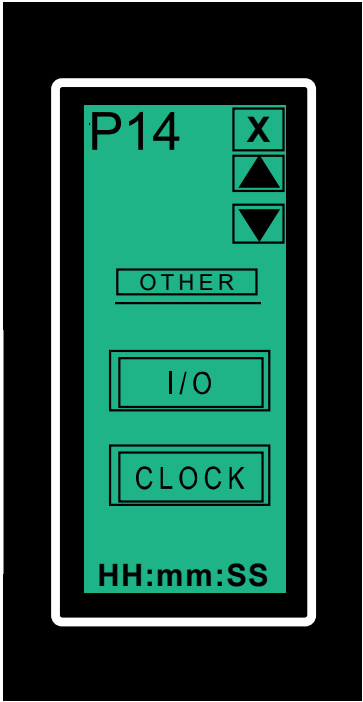

Factory
Setting:

NO
YES

NO
NO

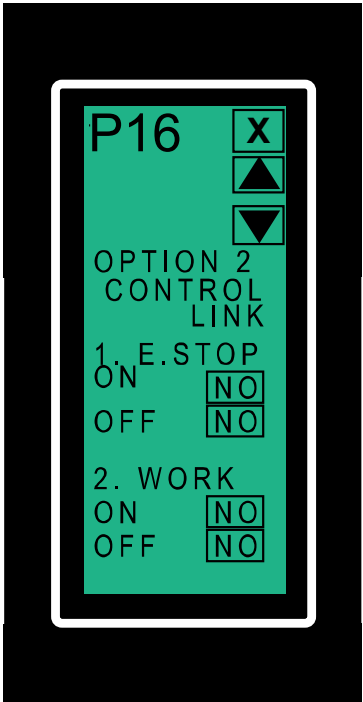

Factory
Setting:

NO
YES

NO
NO



Factory Setting: NO USE

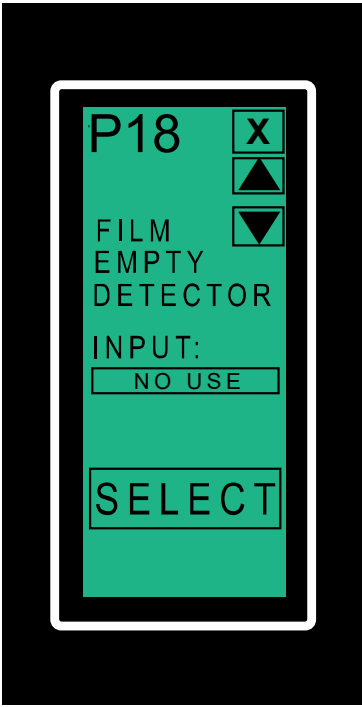

Factory Setting: NO USE

Pressing the "SELECT" key can change it input point of the PLC

Exploded Assembly Diagrams

ITEM	PARTS NO.	PARTS NAME	SEE A DIAGRAM NO.	QTY
A1		Base	LE100T-M01	1
A2		Plate	LE100T-M20	1
A3		Cutter seat	LE100T-M22	1
A4		Motor seat	LE100T-M23	1
A5		Adjusting block	LE100T-M28	1
A6		Cutter seat	LE100T-M29	1
A7		Cutter shaft	LE100T-M42	1
A8		Adjusting rod-1	LE100T-M39	1
A9		Guide bar	LE100T-L01	2
A10		Adjusting screw	LE100T-L02	1
A11		Bar	LE100T-L13	2
A12		Adjusting rod	LE100T-M38	1
A13		Bracket	LE100T-C01	1

ITEM	PARTS NO.	PARTS NAME	SEE A DIAGRAM NO.	QTY
1	5AB04KBL510NC	Sensor	KBL510N-C	1
2	5BC461314	Fixture	13114	2
3	5BE0151102	Thinust bearing	51102	1
4	5BE06SFPJ25	Self lubricating bearing	SFPJ25	4
5	5BC471315	T-clip	13115	1
6	5BC01FR65	Handle	FR65	1

Drawing name	LE100T	Date	10.07.2014	Scale		Check	Design	Draw
Drawing No	wrap enters area	Units	MM					Amy

1916



ITEM	PARTS NO.	PARTS NAME	SIZE & DIAGRAM NO.	QTY
B1		Block	LE100T-M35	1
B2		Sensor seat	LE100T-M36	1
B3		Block	LE100T-M37	1
B4		Adjusting rod-1	LE100T-M39	1
B5		Adjusting screw	LE100T-L27	1
B6		Guide bar	LE100T-L28	1
B7		Handle	LE100T-L31	1
B8		Bracket	LE100T-C02	1
B9		Nylon ring	LE100T-L30	4
B10		Roller base	LE100T-M34	2
B11		Cover	LE100T-P01	1
B12		Cover	LE100T-P04	1
B13		Cutter	LE100T-C10	1
B14		Cutter	LE100T-P16	1
B15	4503314	Cutter	LE100T-P15	1
B16	4503315	Cutter	LE100T-P14	1
B17		Cutter	LE100T-M33	1
B18	4503316	Seat	LE100T-M25	1
B19		Shaft	LE100T-L25	2
B20		Roller	LE100T-L24	2

ITEM	PARTS NO.	PARTS NAME	SIZE & DIAGRAM NO.	QTY
1	5AB04WF500B410	Sensor	WF5-4DB410	1
2	5AG13201	Ventilator filtration	FU.8812	1
3	5AE05T RT244R0GW	Caution light	TR1-24V-4	1
4	5BE010606ZZ	Ball bearing	606ZZ	4
5	5BC4713 115	T-clip	13115	1
6	5ABB4GL6GN1212+P250F	Sensor	GL6G-NE12+P250F	1
7	5BC4514104	Door hub	14104	2

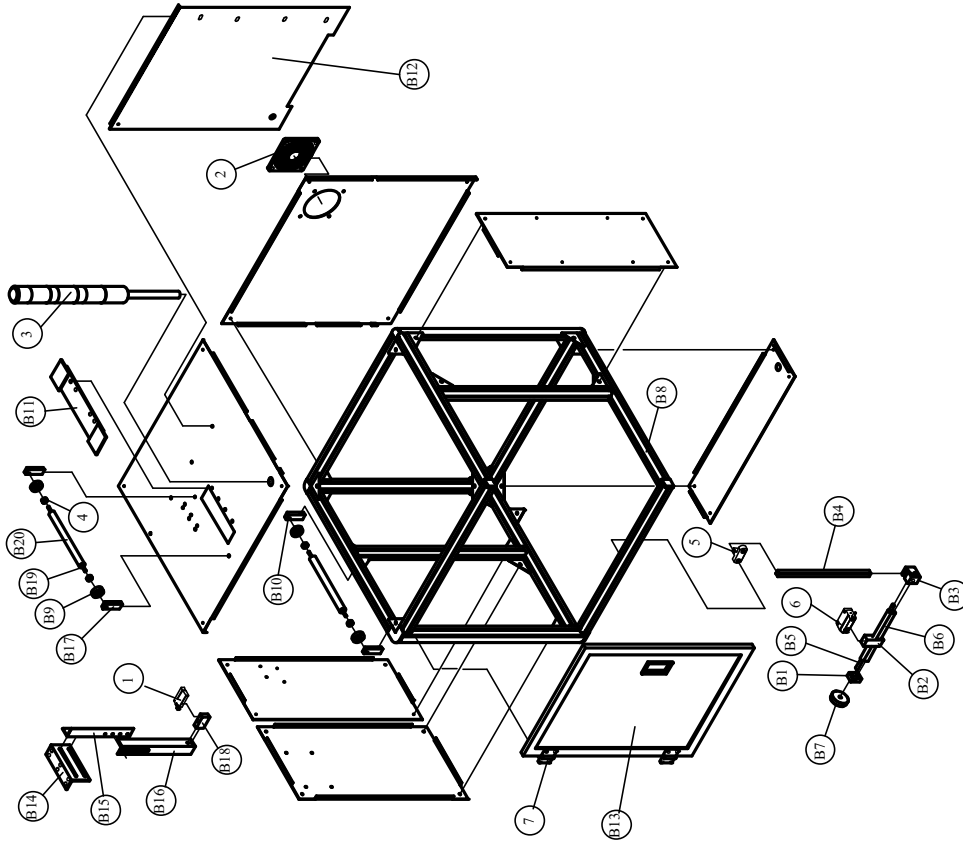

	Drawing name		LE100T	Scale		Date	07.30.2015	Check	Design	Draw
	Drawing No		wrap enters area	Units	MM					

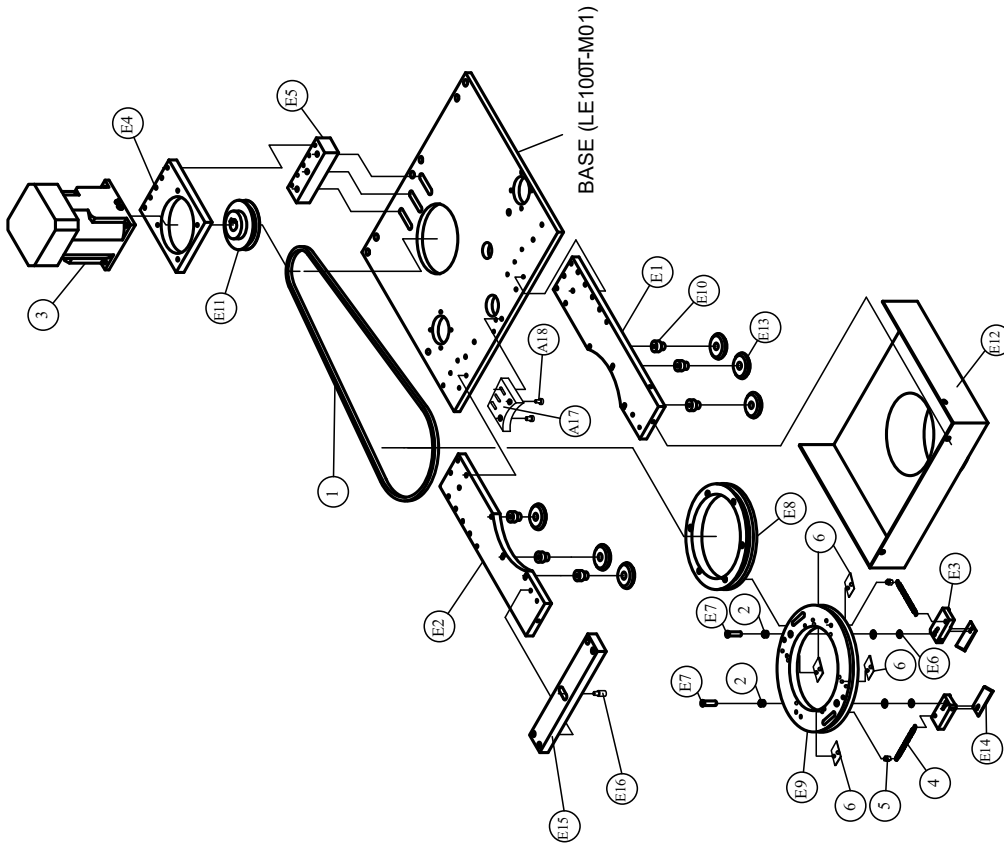

ITEM	PARTS NO.	PARTS NAME	SIZE & DIAGRAM NO.	QTY
E1		Plate	LE100T-M02	1
E2		Plate	LE100T-M03	1
E3		Cutter seat	LE100T-M21	2
E4		Motor seat	LE100T-M24	1
E5		Adjusting block	LE100T-M25	1
E6		Spacing piece	LE100T-L03	2
E7		Cutter shaft	LE100T-L04	2
E8		Pulley	LE100T-L15	1
E9		Cutter disc	LE100T-L16	1
E10		Bearing seat	LE100T-L17	6
E11		Pulley	LE100T-L23	1
E12		Cover	LE100T-P08	1
E13	5JLE100C06	Rubber bearing	LE100T-C06	6
E14	5EA651.0X18X64	Cutter	LE100T-C11	2
E15		Rubber bearing	LE100T-M44	1
E16		Cutter	LE100T-M46	1
E17		Bearing base1	LE100T-M43	1
E18		Bearing base1	LE100T-M45	2

ITEM	PARTS NO.	PARTS NAME	SIZE & DIAGRAM NO.	QTY
1	5BB04M41	Belt	M-41	1
2	5BE010696ZZ	Ball bearing	696ZZ	4
3	5CD39ECMAC20807ES	Servo motor	ECMA-C20807ES	1
4	5EH130.6X08X70X115N	Spring	0.6T X 8 X 7.0 X 115N	2
5	5EE51BSF06M4	Galvanized Nuts	BFS-06M4	2
6		Pad		4

	Drawing name	LE100T	Units	MM	Scale		Date	07.10.2014	Check	Design	Draw
	Drawing No										Amy

The diagram illustrates the exploded assembly of the LE100T mechanism. It shows the following components and their callouts:

- Handle:** F1
- Thrust bearing:** F2
- Ball bearing:** F3
- Motor:** F4
- TRT40:** F5
- Scale:** F6
- Adjusting block:** F7
- Block:** F8
- Cover:** F9
- Rubber bearing:** F10
- Adjusting screw:** F11
- Guide bar:** F12
- Bearing block:** F13
- Bar:** F14
- Cover:** F15
- Rubber roller:** F16
- Bar:** F17
- Block:** F18
- Block:** F19
- Block:** F20

ITEM	PARTS NO.	PARTS NAME	SIZE & DIAGRAM NO.	QTY
F1		Adjusting block	LE100T-M11	1
F2		Block	LE100T-M12	1
F3		Plate	LE100T-M13	1
F4		Plate	LE100T-M14	1
F5		Plate	LE100T-M15	2
F6		Motor seat	LE100T-M16	1
F7		Motor seat	LE100T-M17	1
F8		Adjusting block	LE100T-M18	1
F9		Adjusting block	LE100T-M19	1
F10		Locating block	LE100T-M31	1
F11		Block	LE100T-M32	2
F12		Cover	LE100T-L05	1
F13		Rubber bearing	LE100T-L06	2
F14		Adjusting screw	LE100T-L07	1
F15		Guide bar	LE100T-L14	2
F16		Bearing block	LE100T-L26	2
F17		Bar	LE100T-L29	2
F18		Cover	LE100T-P06	1
F19	5HFQLB100FM13	Rubber roller	LE100T-C07	2
F20		Bar	LE100T-L34	2

ITEM	PARTS NO.	PARTS NAME	SIZE & DIAGRAM NO.	QTY
1	5BC01KRN80	Handle	KRN-80	2
2	5BE0151100	Thrust bearing	51100	1
3	5BE016802ZZ	Ball bearing	6802ZZ	4
4	5CH013K15ACT	Motor	H-3K15A-CT	2
5	5BC02TRT40M6X20	TRT40	M-41	2
6	5EL0406013400	Scale	0.6T X 13 X 4.00 mm	1

Drawing name	Units	Scale	Date	Check	Design	Draw
LE100T wrap enters area	MM		07.10.2014			Amy



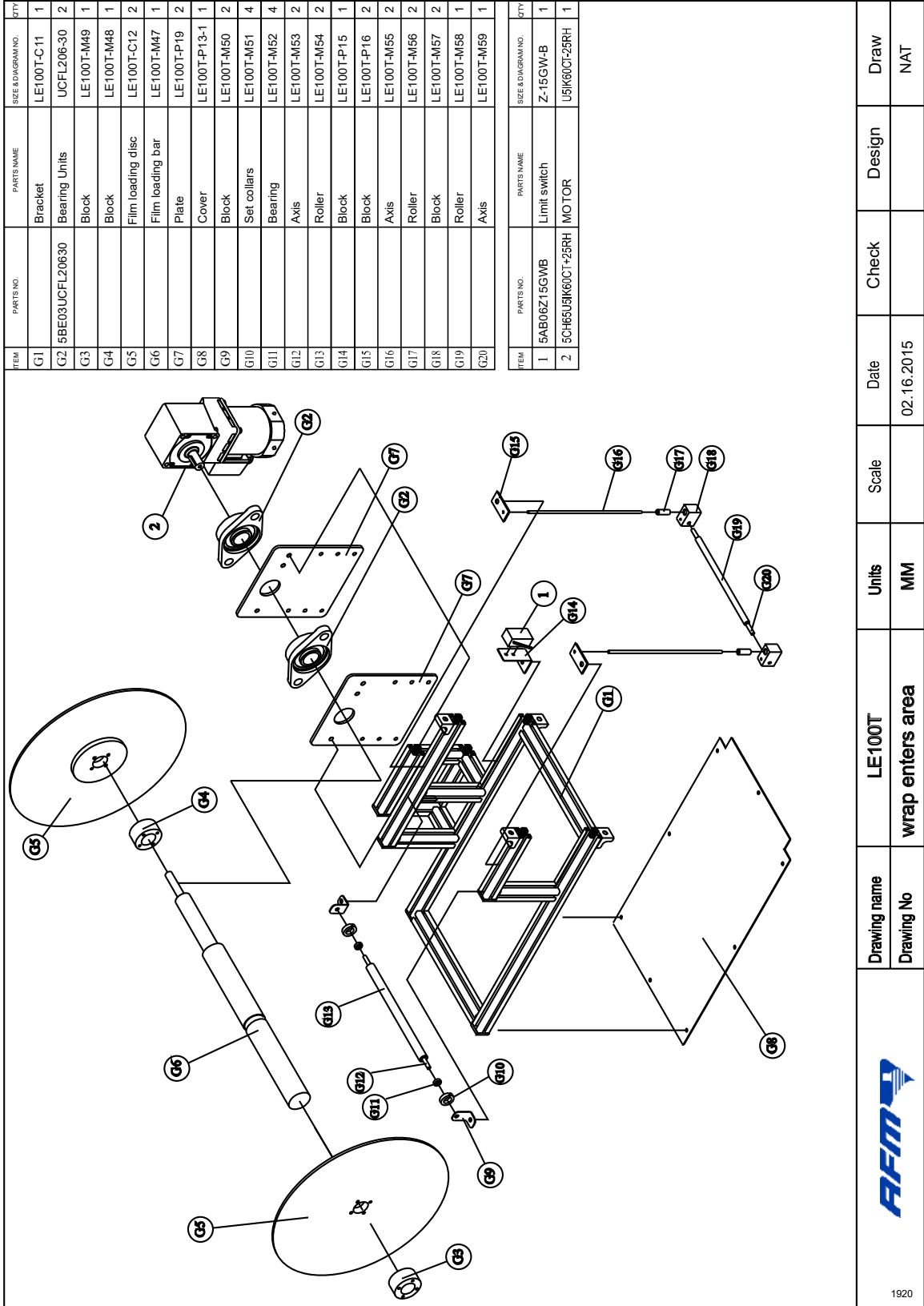

ITEM	PARTS NO.	PARTS NAME	SEE DIAGRAM NO.	QTY
G1		Bracket	LE100T-C11	1
G2	5BE03UCFL20630	Bearing Units	UCFL206-30	2
G3		Block	LE100T-M49	1
G4		Block	LE100T-M48	1
G5		Film loading disc	LE100T-C12	2
G6		Film loading bar	LE100T-M47	1
G7		Plate	LE100T-P19	2
G8		Cover	LE100T-P13-1	1
G9		Block	LE100T-M50	2
G10		Set collars	LE100T-M51	4
G11		Bearing	LE100T-M52	4
G12		Axis	LE100T-M53	2
G13		Roller	LE100T-M54	2
G14		Block	LE100T-P15	1
G15		Block	LE100T-P16	2
G16		Axis	LE100T-M55	2
G17		Roller	LE100T-M56	2
G18		Block	LE100T-M57	2
G19		Roller	LE100T-M58	1
G20		Axis	LE100T-M59	1

ITEM	PARTS NO.	PARTS NAME	SEE DIAGRAM NO.	QTY
1	5AB06Z15GWB	Limit switch	Z-15GW-B	1
2	5CH65UBK60CT-25RH	MOTOR	U5K60CT-25RH	1

Drawing name	LE100T	Date		Check	Design	Draw
Drawing No	wrap enters area	02.16.2015	Scale			NAT
			Units	MM		



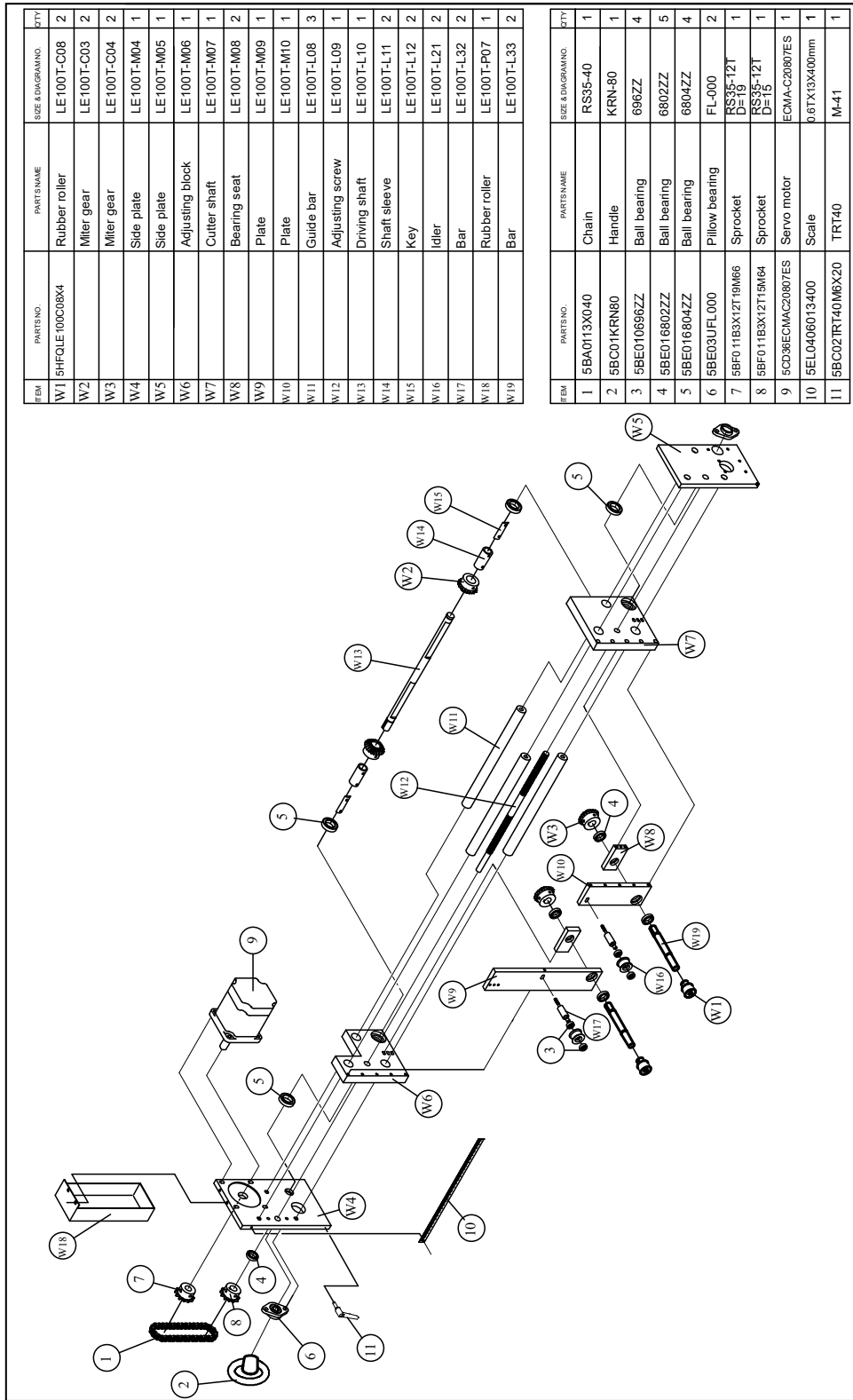

ITEM	PARTS NO.	PARTS NAME	SIZE & DIAGRAM NO.	QTY
W1	5HF0LE100C08X4	Rubber roller	LE100T-C08	2
W2		Miter gear	LE100T-C03	2
W3		Miter gear	LE100T-C04	2
W4		Side plate	LE100T-M04	1
W5		Side plate	LE100T-M05	1
W6		Adjusting block	LE100T-M06	1
W7		Cutter shaft	LE100T-M07	1
W8		Bearing seat	LE100T-M08	2
W9		Plate	LE100T-M09	1
W10		Plate	LE100T-M10	1
W11		Guide bar	LE100T-L08	3
W12		Adjusting screw	LE100T-L09	1
W13		Driving shaft	LE100T-L10	1
W14		Shaft sleeve	LE100T-L11	2
W15		Key	LE100T-L12	2
W16		Idler	LE100T-L21	2
W17		Bar	LE100T-L32	2
W18		Rubber roller	LE100T-P07	1
W19		Bar	LE100T-L33	2

ITEM	PARTS NO.	PARTS NAME	SIZE & DIAGRAM NO.	QTY
1	5BA0113X040	Chain	RS35-40	1
2	5BC01KRN80	Handle	KRN-80	1
3	5BE010696ZZ	Ball bearing	696ZZ	4
4	5BE016602ZZ	Ball bearing	6802ZZ	5
5	5BE016604ZZ	Ball bearing	6804ZZ	4
6	5BE03UFL000	Pillow bearing	FL-000	2
7	5BF011B3X12T19M66	Sprocket	RS35-12T D=19	1
8	5BF011B3X12T15M64	Sprocket	RS35-12T D=15	1
9	5CD36ECCMAC20807ES	Servo motor	ECMA-C20807ES	1
10	5EL0406013400	Scale	0.01X13X400mm	1
11	5BC02TRT40M6X20	TRT40	M-41	1

	Drawing name	LE100T	Units	MM	Scale		Date	06.10.2014	Check	Design	Draw
	Drawing No	wrap enters area									Amy

Schematic Diagrams

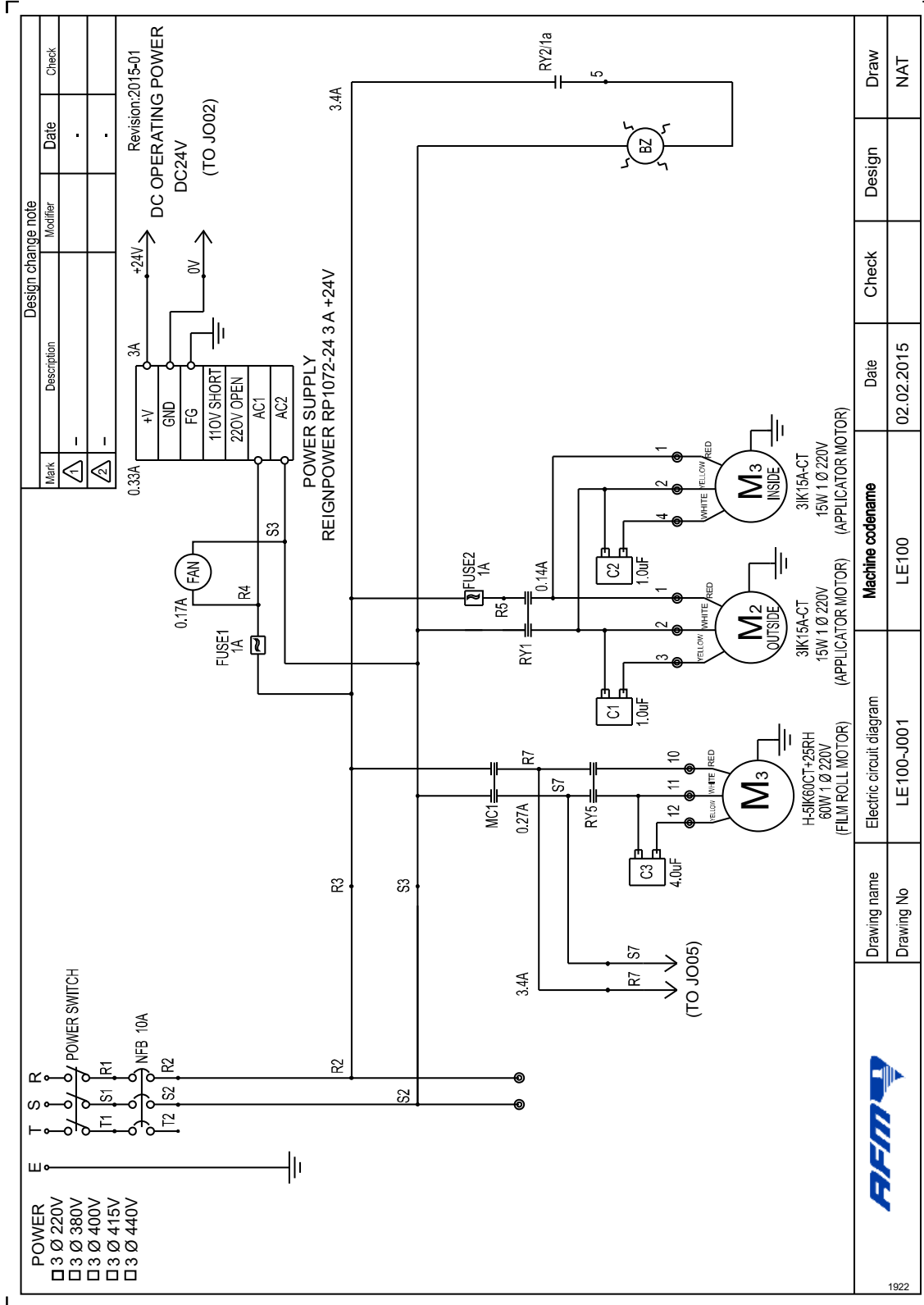

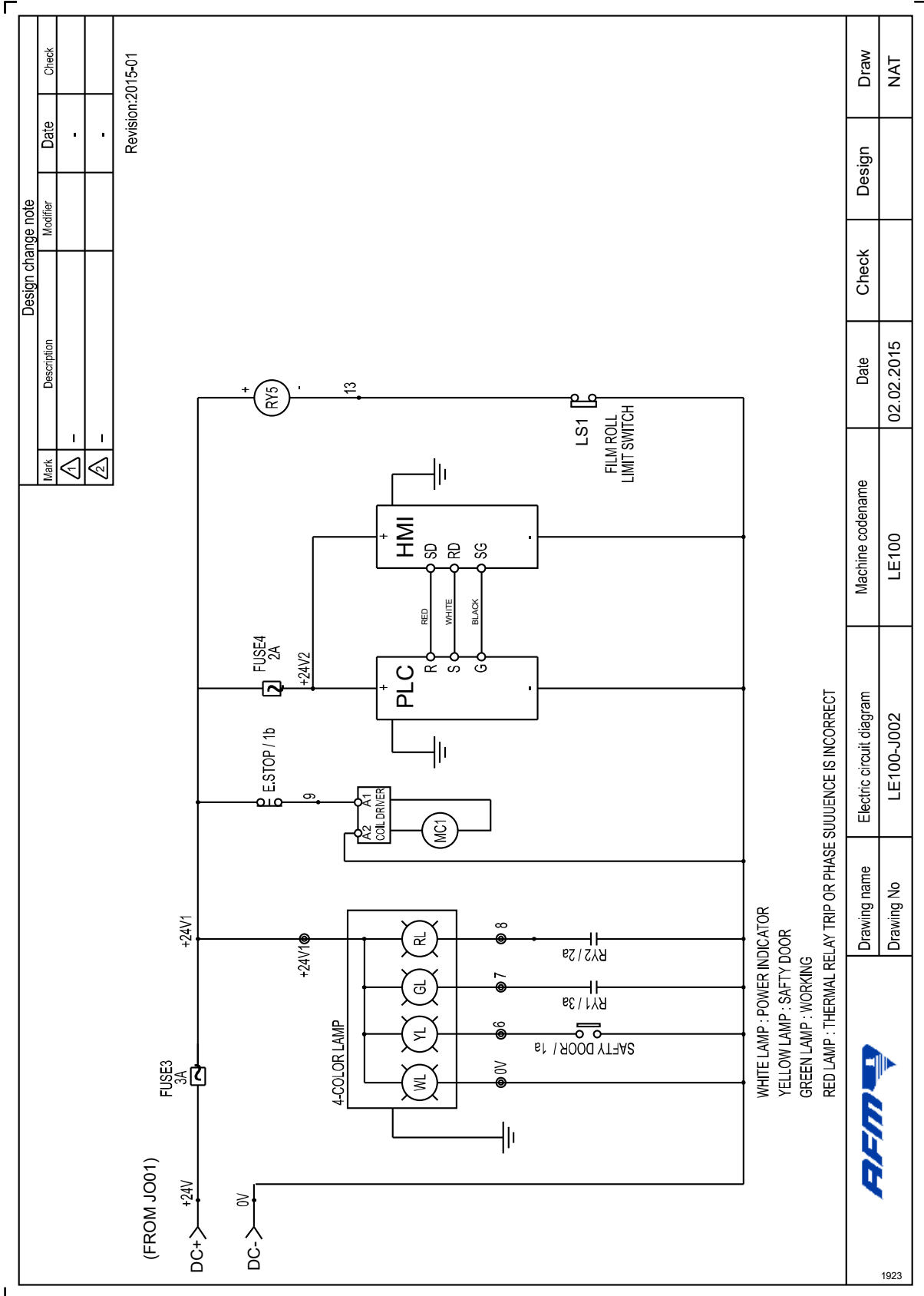

Design change note			
Mark	Description	Modifier	Check
△	-	-	-
△	-	-	-

Revision:2015-01

	Drawing name	Machine codename	Date	Check	Design	Draw
	Drawing No	LE100-J002	02.02.2015			NAT

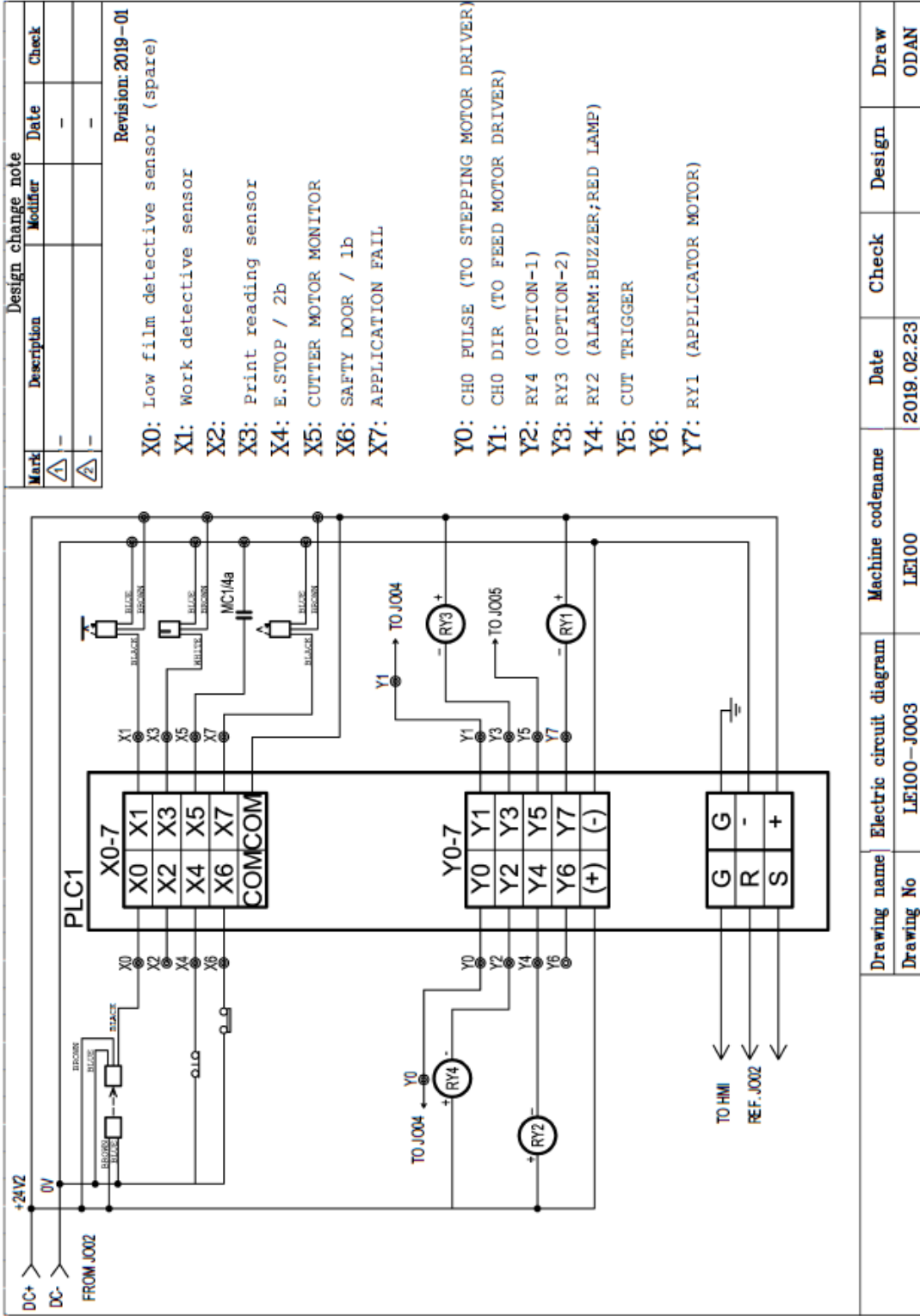

Drawing name	Electric circuit diagram	Machine codename	Date	Check	Design	Draw
Drawing No	LE100-J003	LE100	2019.02.23			ODAN

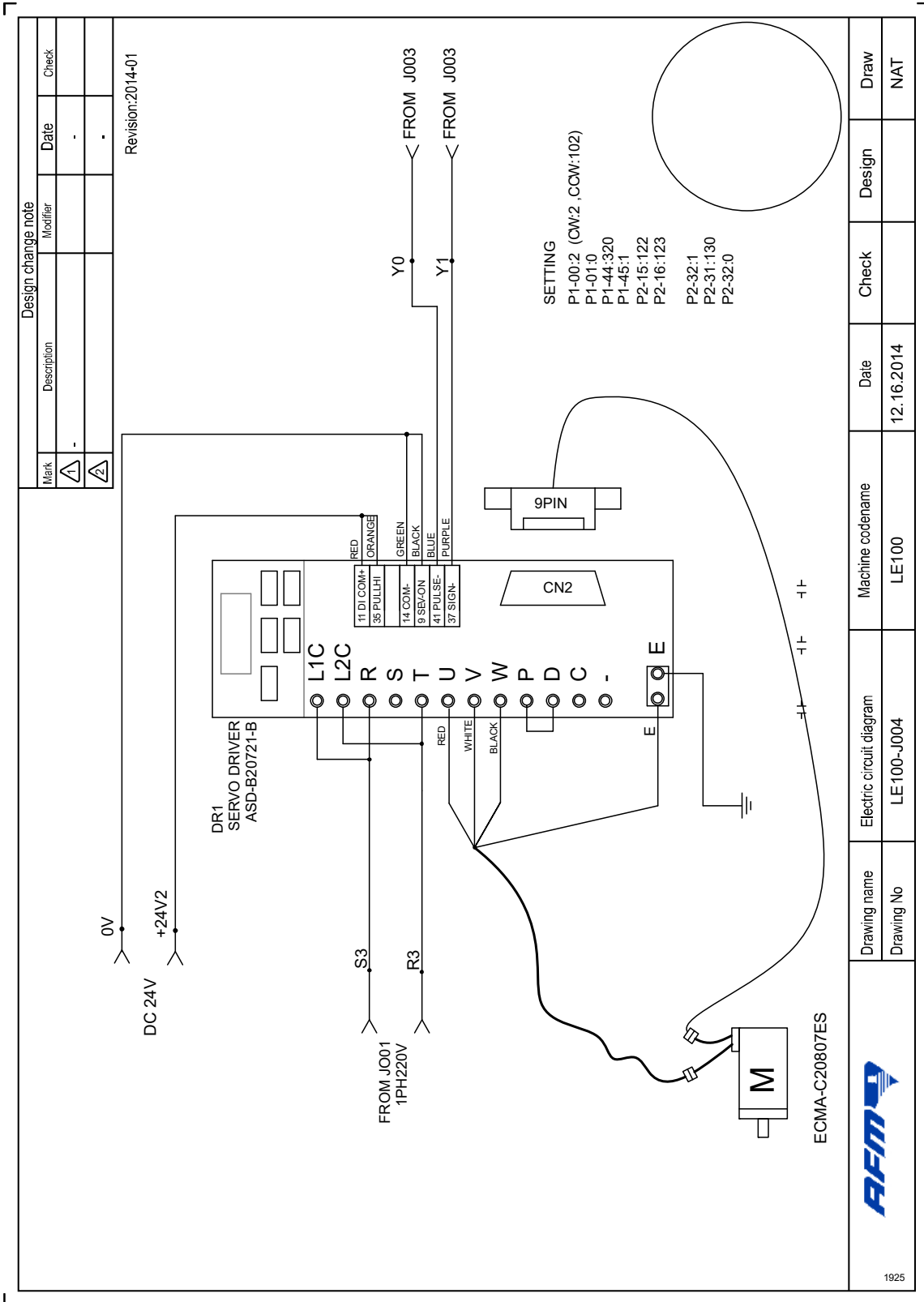

Drawing name		Machine codename	Date	Check	Design	Draw
Drawing No		LE100-J004	12.16.2014			NAT
		LE100				
Electric circuit diagram						



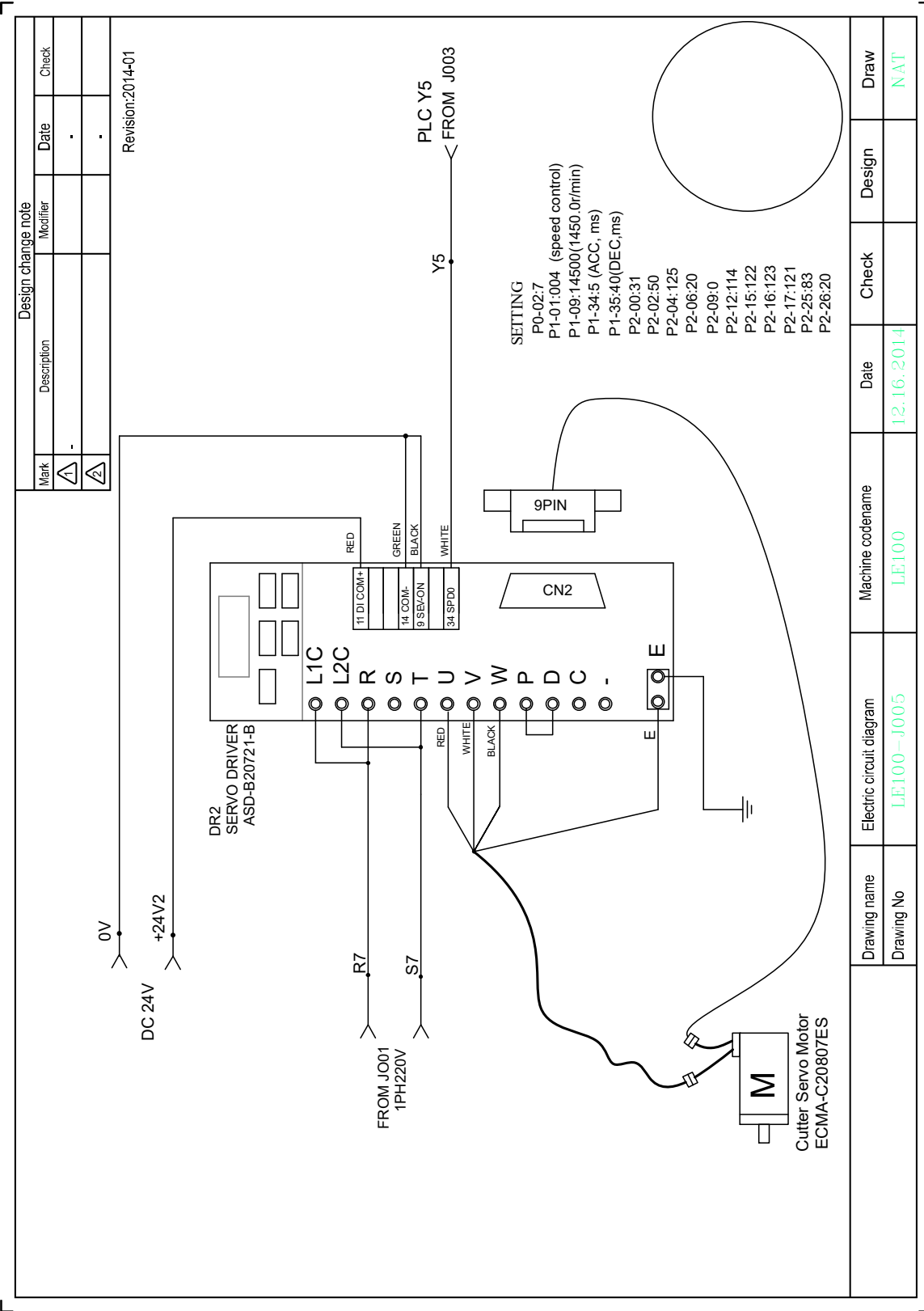

80 Schematic Diagrams

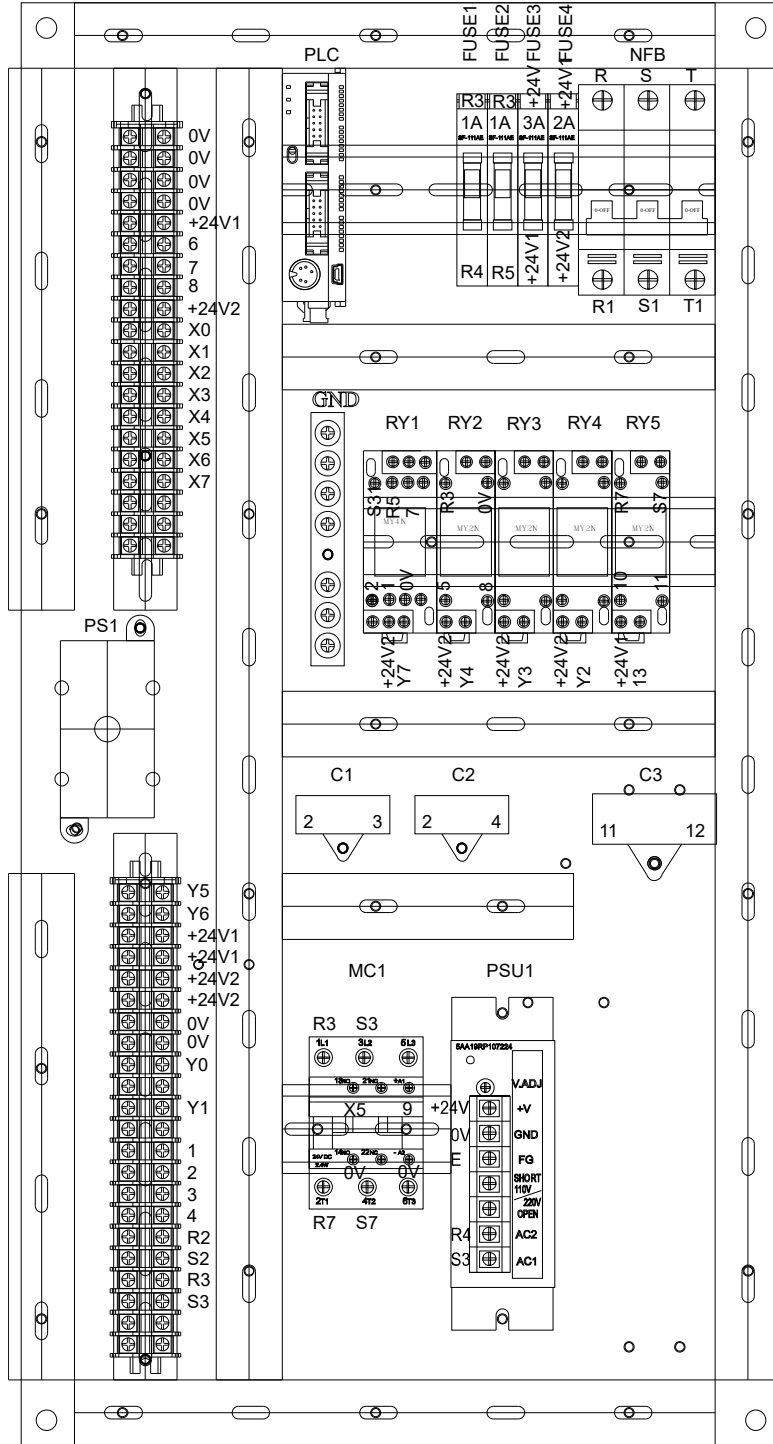

Optional

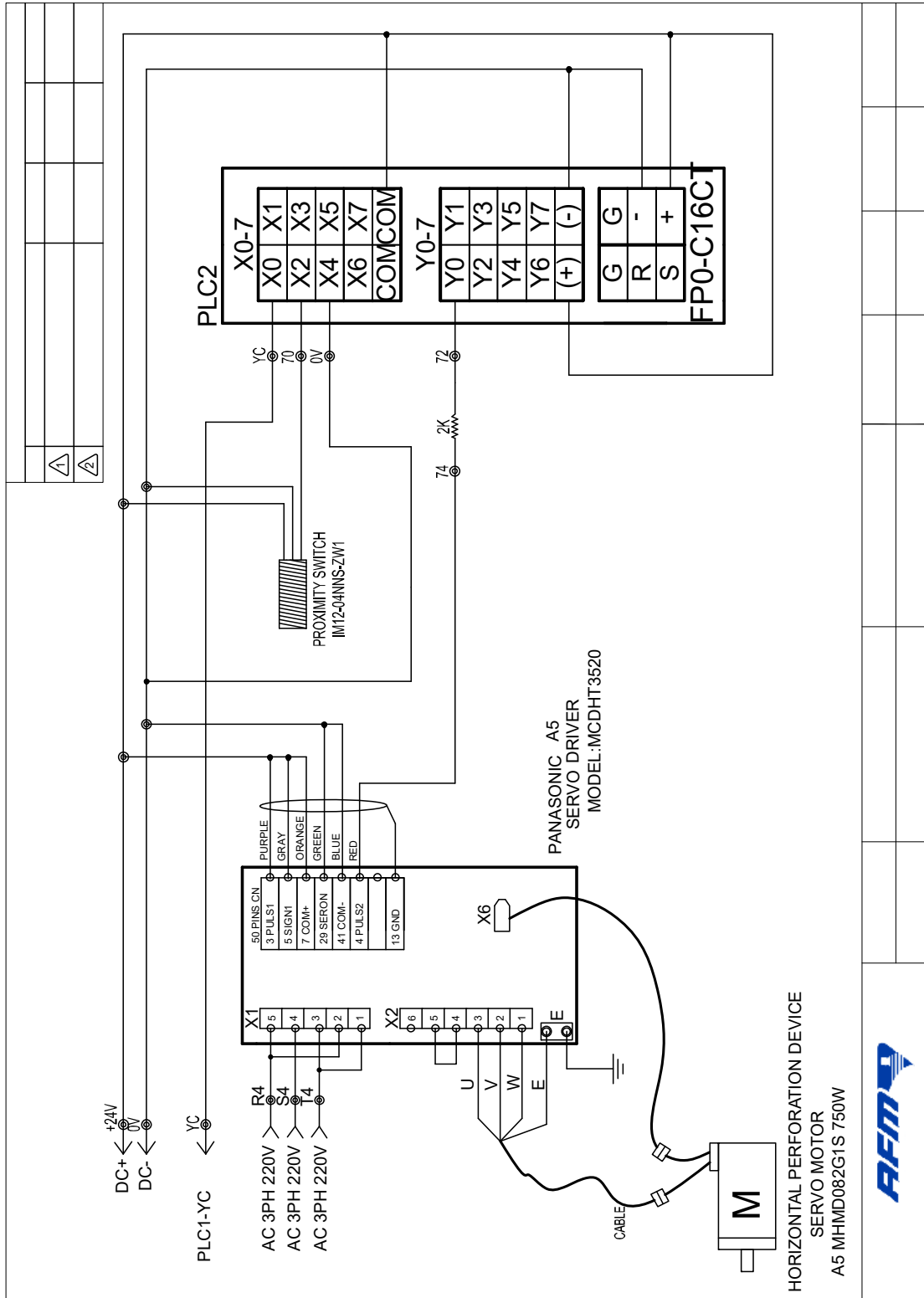

SERVO MOTOR DRIVER

MODEL: MCDT3520

50PIN CONNECTOR

26	28	30	32	34	36	38	40	42	44	46	48	50
VS-SEL	DIV	CL	C-	S-	ALM-	COIN-	TLC	IM	PULSH1	SIGNH1	OB+	FG
MODE	RDY-											
27	29	31	33	35	37	39	41	43	45	47	49	
GAIN	SRV	A-	INH	S-	ALM+	COIN+	COM-	SP	PULSH2	SIGNH2	OB-	
-ON	CLR											
1	3	5	7	9	11	13	15	17	19	21	23	25
NC	PULS1	SIGN1	COM+	CCWL	BRK-	GND	GND	GND	CZ	OA+	OZ+	GND
					OFF+							
2	4	6	8	10	12	14	16	18	20	22	24	
NC	PULS2	SIGN2	CWL	BRK-	ZSP	TRQH	CCWTL	CWTL	NC	OA-	OZ-	
					OFF-							

SETTING METHOD

DISPLAY : r0
 PRESS "SET"
 DISPLAY : dp-Spd
 PRESS "MODE"
 DISPLAY : PA-00
 PRESS \odot 7TIMES
 DISPLAY : PA-007
 PRESS "SET"
 PRESS \odot TO MODIFY ,FACTORY SETTING :3
 PRESS "SET"
 DISPLAY : PA-007
 PRESS "MODE"
 DISPLAY : EE-SET (SAVE TO EEPROM)
 PRESS "SET"
 DISPLAY : EEP-
 PRESS \odot AND HOLD IT, TILL SHOW "RESET"
 AND RESET IT

FACTORY SETTING

PA-000 : 0 (0:CW;1:CCW)
 PA-001 : 0
 PA-007 : 3 (PULSE+ SIGNAL)
 PA-008 : 500 (500PULSE/CIRCLE)
 PA-002 : 1
 PA-003 : 20
 FINISH PA-002:0

WIRE COLOR	50PIN NO#	FUNCTION	WIRE NO#
ORANGE	7	COM+	+24V
GREEN	29	SERON	0V
PURPLE	3	PULS1	+24V
RED	4	PULS2	74
GREY	5	SIGN1	+24V
BULE	41	COM-	0V
shield	13	GND	



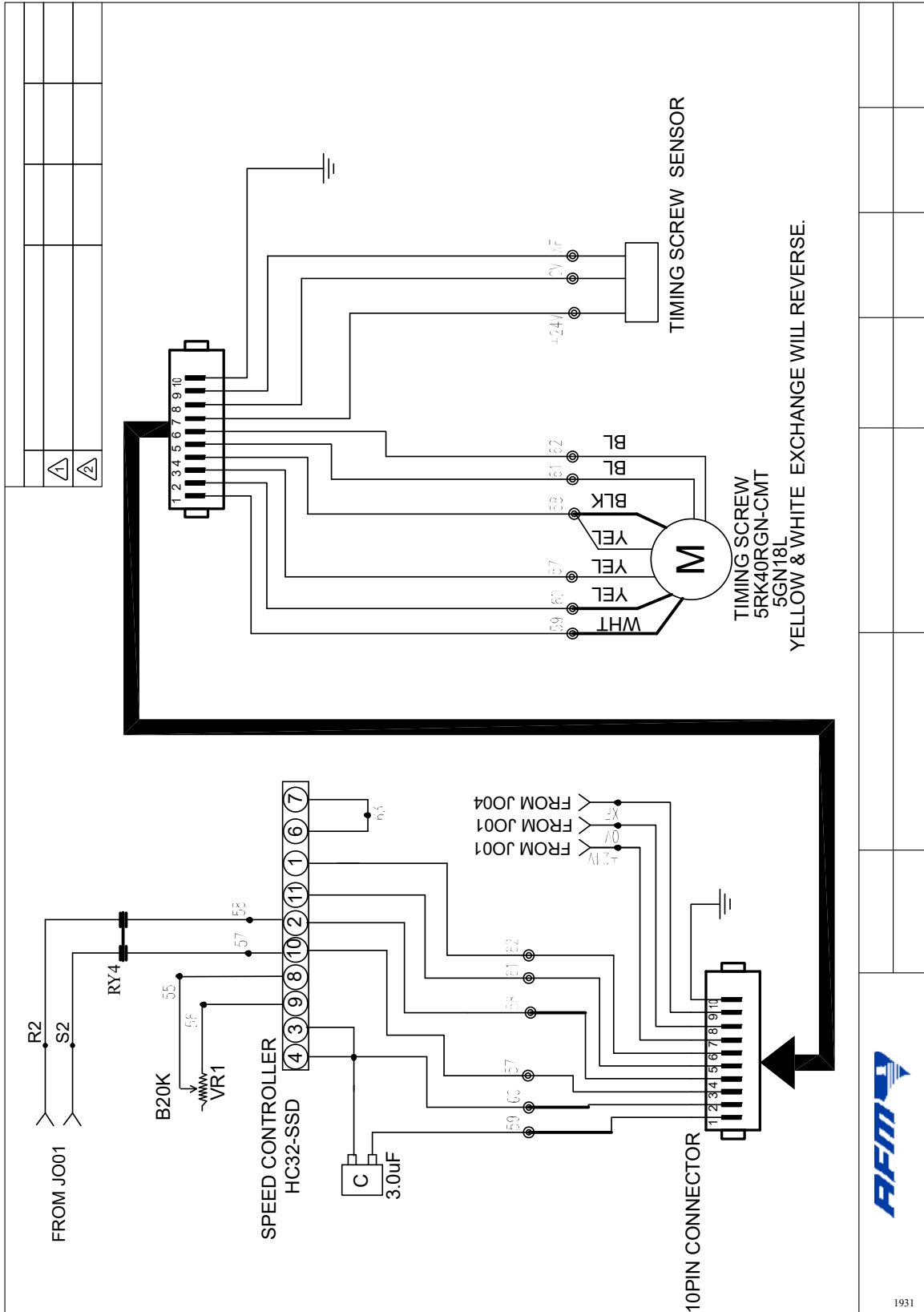

Parts List

Cutting Device Page 84

No.	Part Number	Description	Size and Diagram Number	Qty.
01	5BB04M41	Belt	M-41	1
02	5BE010696ZZ	Ball Bearing	696ZZ	4
03	5CF12CDM06	Clutch brake set	CD-M-0.6	1
04	5CF414PAXP4	Motor	4P,1/4 HP,3 PHASE	1
05	5FA034X6BXM	PU Tube	6 X 4 mm	2
06	5FA0310X6.5BXM	PU Tube	10 X 6.5 mm	2
07	5FA038X12BXM	PU Tube	12 X 8 mm	2
08	5JL01M01	Plate	LE100-M02	1
09	5JL01M01	Plate	LE100-M03	1
10	5JL01M01	Cutter seat	LE100-M21	2
11	5JL01M01	Motor seat	LE100-M24	1
12	5JL01M01	Adjusting block	LE100-M25	1
13	5JL01M01	Spacing piece	LE100-L03	2
14	5JL01M01	Cutter shaft	LE100-L04	2
15	5JL01M01	Pulley	LE100-L15	1
16	5JL01M01	Cutter disc	LE100-L16	1
17	5JL01M01	Bearing seat	LE100-L17	6
18	5JL01M01	Pulley	LE100-L23	1
18	5JL01P01	Cover	LE100-P08	1
20	5JLE100C06	Rubber bearing	LE100-C06	6
21	5V0320X1	Cutter	1X18X64 SKH	2
22	5V0551	Spring	KA0421-01 D0.6*0D8*L85	2

Insert Device Page 85

Part Number	Description	Size and Diagram Number	Qty.
5BC01KRN80+CB50	Handle	KRN-80	2
5BE0151100	Thrust bearing	51100	1
5BE016802ZZ	Ball bearing	6802ZZ	4
5CH0131K15AC	Motor	3IK15A-C	2
5EL0406013200	Scale	0.6T X 13 X 200 mm	1
5EL0406013400	Scale	0.6T X 13 X 400 mm	1
5JL01M01	Adjusting block	LE100-M11	1
5JL01M01	Block	LE100-M12	1
5JL01M01	Plate	LE100-M13	1
5JL01M01	Plate	LE100-M14	1
5JL01M01	Plate	LE100-M15	2
5JL01M01	Motor seat	LE100-M16	1
5JL01M01	Motor seat	LE100-M17	1
5JL01M01	Adjusting block	LE100-M18	1
5JL01M01	Adjusting block	LE100-M19	1
5JL01M01	Locating block	LE100-M31	1
5JL01M01	Block	LE100-M32	2
5JL01M01	Adjusting screw	LE100-L05	1
5JL01M01	Guide bar	LE100-L06	2
5JL01M01	Adjusting screw	LE100-L07	1
5JL01M01	Guide bar	LE100-L14	2
5JL01M01	Bearing block	LE100-L26	2
5JL01M01	Bar	LE100-L29	2
5JL01P01	Cover	LE100-P06	1
5JLE100C07	Rubber roller	LE100-C07	2

Supply Device Page 87

Part Number	Description	Size and Diagram Number	Qty.
5BA0113X040	Chain	RS35-40	1
5BC01KRN80+CB50	Handle	KRN-80	1
5BE010696ZZ	Ball bearing	696ZZ	4
5BE016802ZZ	Ball bearing	6802ZZ	6
5BE016804ZZ	Ball bearing	6804ZZ	4
5BE03UFL000	Pillow bearing	FL-000	1
5BF011B3X12T14M6	Sprocket	RS35-12T	1
5BF011B3X12T15M64	Sprocket	RS35-12T	1
5CB04PK599AW	Stepping motor	PK599AW	1
5EL0406013400	Scale	0.6T X 13 X 400 mm	1
5JLE100C08	Rubber roller	LE100-C08	2
5AB04WF2B4210	Sensor	WF2-B4210	1
5Y0219X1	Miter gear	LE100-C03	2
5Y0219X2	Miter gear	LE100-C04	2
5JL01M01	Side plate	LE100-M04	1
5JL01M01	Side plate	LE100-M05	1
5JL01M01	Adjusting block	LE100-M06	1
5JL01M01	Adjusting block	LE100-M07	1
5JL01M01	Bearing seat	LE100-M08	2
5JL01M01	Plate	LE100-M09	1
5JL01M01	Plate	LE100-M10	1
5JL01M01	Sensor seat	LE100-M26	2
5JL01M01	Adjusting block	LE100-M27	2
5JL01M01	Guide bar	LE100-L08	3
5JL01M01	Adjusting screw	LE100-L09	1
5JL01M01	Driving shaft	LE100-L10	1
5JL01M01	Shaft sleeve	LE100-L11	2
5JL01M01	Key	LE100-L12	2
5JL01M01	Idler	LE100-L21	2
5JL01M01	Bar	LE100-L20	2
5JL01P01	Cover	LE100-P07	1

Film Loading Device

Part Number	Description	Size and Diagram Number	Qty.
5BC02TRT40M6X20	Handle screw	TRT40	2
5BC4514104	Hinge	14104	2
5BE010606ZZ	Ball bearing	606ZZ	8
5Y0551	Spring	KA0421-01 D0.6XOD8XL85	1
5JL01M01	Plate	LE100-M30	2
5JL01M01	Roller seat	LE100-M33	2
5JL01M01	Roller seat	LE100-M34	2
5JL01M01	Brake bar	LE100-M41+silicon hose	1
5JL01M01	Block	LE100-L18	2
5JL01M01	Dancer bar	LE100-L22	1
5JL01M01	Roller	LE100-L24	3
5JL01M01	Shaft	LE100-L25	3
5JL01M01	Locating ring	LE100-L30	6
5JL01M01	Distribution door	LE100-P03	1
5JL01M01	Film loading box	LE100-P05	1
5JLE100C09	Film loading disc	LE100-C05	2
5JLE100L19	Film loading bar	LE100-L19	1
5AB04E3R5E4	Sensor	E3R-5E4	1
5JLE100L19		LE100-L19	1

Main Head Device

Part Number	Description	Size and Diagram Number	Qty.
5AB04KBLS10NC	Sensor	KBLS10N-C	1
5AB04WL92N131P02	Reflector	WL9-2N131P02	1
5BC4613114	Fixture	13114	2
5BC4713115	T-fixture	13115	1
5BE0151102	Thrust bearing	51102	1
5BE06SFPJ25	Self-lubricating bearing	SFPJ25	4
5EL0406013400	Scale	0.6T X 13 X 400 mm	1
5JL01M01	Base	LE100-M01	1
5JL01M01	Plate	LE100-M20	1
5JL01M01	Plate	LE100-M22	1
5JL01M01	Plate	LE100-M23	1
5JL01M01	Handle	LE100-M28 + FR65	1
5JL01M01	Plate	LE100-M29	1
5JL01M01	Reflector bar	LE100-M38	1
5JL01M01	Bar	LE100-M39	1
5JL01M01	Sensor bar	LE100-M42	1
5JL01M01	Guide bar	LE100-L01	2
5JL01M01	Adjusting screw	LE100-L02	1
5JL01M01	Bar	LE100-L13	2
5JL01 P01	Reflector plate	LE100-P09	1
5JLE100CC04	Frame	LE100-C01	1

Main Head Device

Part Number	Description	Size and Diagram Number	Qty.
5AB04WL92N131P0	Sensor	WL9-2N131P02	1
5BC4713115	T- Fixture	13115	1
5EL0406013200	Scale	0.6 X 13 X 200mm	1
5JL01M01	Block	LE100-M35	1
5JL01M01	Sensor seat	LE100-M36	1
5JL01M01	Block	LE100-M37	1
5JL01M01	Adjusting bar	LE100-M40	1
5JL01M01	Adjusting screw	LE100-L27	1
5JL01M01	Guide bar	LE100-L28	1
5JL01M01	Handle	LE100-L31	1
5JL01M01	Cover	LE100-P01 + hinge	1
5JL01P01	Cover	LE100-P02	1
5JL01P01	Guard plate	LE100-P04	1
5JL01P01	Distribution box	LE100-P11	1
5JLE100CC04	Head	LE100-C02	1

Warranty Statement AFM Products

Warranty Statement

American Film & Machinery (AFM) warrants that all of the products it ships will be in good working order and free from defects in material and workmanship for a period of one year from the date of shipment by AFM and will conform to the published specifications for that product.

Limitations

The warranty of AFM is contingent upon installation, operation, and maintenance of equipment under normal operating conditions. The warranty is void on equipment or parts: damaged by corrosion, improper use, accident, negligence or not operating within the specifications provided; damaged by fire, flood, earthquake, or such other causes beyond the control of AFM; that have been altered or repaired in any way changing the original performance and; that are normally expendable in the usual course of operation. Expendable items include, but are not limited to, heater elements, cutter blades and belts. The warranty period on each replacement equipment or part in fulfillment of the warranty on new equipment or parts shall be for the unexpired portion of the original warranty.

Repairs

All in-house repairs are rigorously tested for optimum operation and performance and warranted to be, under normal and proper use, free from defects in material and workmanship for a period of 90 days from the date of service.

Shrinking Quality

Shrinking quality achieved in a given application is dependent on the film, product, installation, material handling, and the maintenance provided. AFM makes no warranty that the shrinking quality achieved in an application will be the same as that achieved on a test piece in our demo facility.

Shipping Policy

Customer pays all incoming shipping charges for replacement components. If the item is defective and under warranty, AFM will pay all return shipping charges via the least costly method. If expedited shipping is desired, the customer must furnish their shipping account number and shipping fees will be charged to that account.

Exclusions

Damage due to tampering, abuse, improper adjustment, electrical interference, or the use of non-approved components will void any and all warranties by AFM and its distributors.



Warranty Verification

If you believe that a product or component may be defective and may be covered by warranty, obtain a Return Material Authorization number by calling our technical support number (toll free at 1-800-835-9344, or 763-428-4846 or Fax: 763-795-8867) or e-mail: info@afmsleeves.com. Based on the recommendation from AFM technical support, replacement components may be shipped out via UPS Ground or similar method. If expedited shipping is desired, customer must furnish their shipping account and shipping fees will be charged to that account.

Customer is required to return the defective component to AFM. If, after 30 days, AFM hasn't received the defective component, the customer will be invoiced for the replacement component. If the returned component is found to not be eligible for warranty, AFM will contact the customer, and the customer will be invoiced for the replacement component.

Warranty within 60 days of invoice

For warranty questions that take place within 60 days of the original invoice, AFM will allow cross-shipment of a replacement component to an end-user customer or AFM distributor. The customer will be invoiced for the replacement component 60 days after it ships. Upon receipt of the returned component, AFM will evaluate it and issue credit where necessary.

For components that have been misused or externally damaged, AFM will not issue credit, and will contact the customer to determine whether or not they want the component repaired and/or returned.

Warranty after 60 days of invoice

For warranty questions that take place more than 60 days from the original invoice, AFM requires the end-user or AFM distributor to return the component to AFM for repair. Upon receipt of the returned component, AFM will evaluate it and repair as necessary.

Components that fall within our warranty policy will be repaired normally within 5 business days of receipt and returned to the customer via standard ground shipping at AFM's expense. If expedited shipping is required, the customer must furnish their shipping account number and shipping fees will be charged to that account.

For components that have been misused or externally damaged, AFM will contact the customer to determine whether they want the component repaired and/or returned.

Warranty Eligibility

The warranty provided by AFM is only to the original buyer.

Limited Warranty

THIS WARRANTY SHALL NOT APPLY IF ANY MODIFICATION, ALTERATION OR ADDITION IS MADE TO THE PRODUCT WITHOUT EASTEY'S PRIOR WRITTEN APPROVAL. FURTHERMORE, THIS WARRANTY DOES NOT APPLY TO PRODUCT DEFECTS DUE TO MISUSE, ABUSE, NEGLIGENCE, OR FAILURE TO FOLLOW RECOMMENDED PROCEDURES. ANY PRODUCT REPAIRED OR ALTERED BY PERSONS OTHER THAN AUTHORIZED EASTEY REPRESENTATIVES WILL NOT BE COVERED BY THIS WARRANTY. THIS WARRANTY DOES NOT APPLY TO CONSUMABLE ITEMS.

EXCEPT AS EXPRESSLY PROVIDED IN THIS WARRANTY, EASTEY MAKES NO REPRESENTATION OR WARRANTY, EXPRESSED OR IMPLIED, WITH RESPECT TO THE PRODUCT, INCLUDING, WITHOUT LIMITATION, ANY WARRANTY AS TO MERCHANTABILITY, FITNESS FOR A PARTICULAR PURPOSE, NON-INFRINGEMENT OR ANY OTHER MATTER.

EASTEY SHALL HAVE NO LIABILITY TO ANY PERSON FOR INCIDENTAL, CONSEQUENTIAL, OR SPECIAL DAMAGES OF ANY DESCRIPTION WHETHER ARISING OUT OF WARRANTY OR



94 Warranty Statement

OTHER CONTRACT, NEGLIGENCE OR OTHER TORT, OR OTHERWISE. NO AGENT, EMPLOYEE, OFFICER OR OTHER REPRESENTATIVE OF AFM, INC. HAS AUTHORITY TO BIND EASTEY TO ANY REPRESENTATION OR WARRANTY EXCEPT AS STATED HEREIN. UNDER NO CIRCUMSTANCES SHALL EASTEY'S LIABILITY HEREUNDER, FOR ANY REASON OR CAUSE EXCEED THE PRICE PAID TO EASTEY FOR THE PRODUCT.

Disclaimer of Damages

REGARDLESS OF WHETHER ANY REMEDY SET FORTH HEREIN FAILS OF ITS ESSENTIAL PURPOSE, IN NO EVENT WILL AFM BE LIABLE FOR ANY SPECIAL, CONSEQUENTIAL, INDIRECT, OR SIMILAR DAMAGES, INCLUDING LOST PROFIT OR LOST OPPORTUNITIES OF ANY TYPE ARISING OUT OF THE USE OR INABILITY TO USE THESE PRODUCTS EVEN IF AFM HAS BEEN ADVISED OF THE POSSIBILITY OF SUCH DAMAGES.

Customer Support

AFM Technical Service

For help installing or operating the LX-100, please contact your authorized AFM reseller or AFM Technical Service at one of the numbers listed below.

Phone	714-974-9006
Fax	763-795-8867
E-mail	info@afmsleeves.com
Web	www.afmsleeves.com

Thank you for your purchase of AFM products. We are pleased to be a part of your shrink sleeving needs.



AMERICAN FILM & MACHINERY